

Dutypoint case study: Leamington Gospel Hall

Dutypoint 

Location:
Leamington Spa



PROJECT SUMMARY

Leamington GHT contacted Dutypoint Systems as they were extending their conference centre and adding additional WCs and wash-hand basins. The current site operated via the mains water but with addition usage, there was a need for on site water storage and increasing the pressure throughout the system.

PROJECT CHALLENGE

With a serious lack of plant room space, a standard break tank and booster set wasn't an option.

PRODUCT SOLUTION

Dutypoint Systems QuadraTANK was the perfect option. Providing a single piece break tank and kiosk, suitable for installation externally and available in various sizes to suit whatever application you are working on.

The QuadraTANK installed
at Leamington Gospel Hall

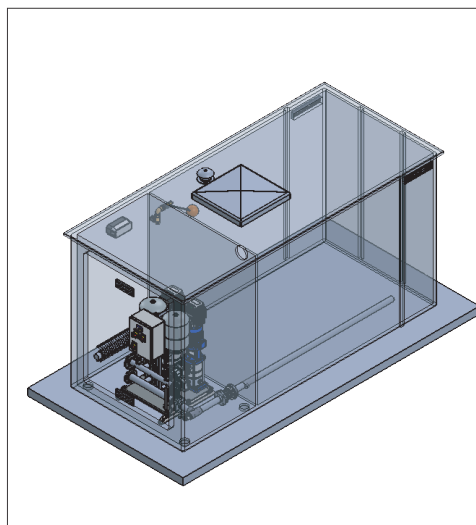

PROJECT NAME

Leamington Gospel Hall

INDUSTRY SECTOR

End user

PROJECT TYPE

Conference Centre

CLIENT

Leamington Meeting Room Trust

PROGRAMME

8 months

COMPLETION

February 2017

PRODUCT SUPPLIED

QuadraTANK