



Electromagnetic Water Conditioners

Operation and Maintenance Manual

DOC-ECOM1701

DUTYPOINT

SETTING
THE BAR

About us.

Applied knowledge.
Shared know-how.
Fearless innovation.

Together, we are Dutypoint. Since 1976, we've been building up industry-defining expertise in fluid technology.

This knowledge means we solve complex challenges with straightforward solutions that are built around meeting and exceeding our clients' needs. We approach everything with the same philosophy: how will we go above and beyond?

Our commitment to collaboration and sharing knowledge galvanises and cements robust relationships. Relationships that are built to last, because our clients are our partners.

Our focus for the future? Innovation. We want to be the future of our industry, globally. Where we benchmark thought leadership, expertise and customer care.

We set the bar.

Contact details.

T: +44(0)1452 300592

E: info@dutypoint.com

Registered Office:

Dutypoint Limited
Shepherd Road
Gloucester
GL2 5EL
United Kingdom

1. Dutypoint EC Specifications

Dutypoint EC electromagnetic water conditioners are the ecological solution to increased life cycle costs associated with the build-up of hard lime scale. The Dutypoint EC reduces energy consumption and extends the life of plant equipment by eliminating the build-up of hard calcareous lime scale, without introducing harmful chemicals or additives. As the EC is a physical water conditioner, water quality is maintained; none of the essential minerals present in potable drinking water are removed through the treatment. The unit is totally maintenance-free, incorporating a simple control box with power-on lamp. The versatile Dutypoint EC operates at up to 16 bar pressure and 23°C and is available in a range of sizes as shown in the table below.

1.1 Standard Technical Features

- Approved for use with potable water
- Treatment effective on stored water for 7 days
- No chemicals or corrosive elements added to water
- Low power consumption
- No wastage of water - regeneration process not required
- No maintenance required
- Working pressure Up to 16 bar
- Multiple units can be installed in parallel to achieve higher flow rates
- Suitable for mounting vertically or horizontally
- Pre-wired, wall-mountable control box with fault lamp and option common fault volt-free contact for connection to building management systems

1.2 Optional Features

- Water metering
- Floor mounting kit
- Wall mounting kit (available on some models)
- Isolation valves
- Bypass assembly
- Particle filtration
- Flanged connections
- Duplex connection kits
- Integration with other Dutypoint products, such as packaged plant rooms and cold water booster sets

1.3 Technical Specifications

Table 1.1: Dutypoint EC Water Conditioner Specification Table

Model	Max Flow Rate (l/sec)	Power (W)	Diameter (mm)	Depth (mm)	Connection Size	Weight (kg)
EC15	0.15	4	130	50	½"	5
EC20-150	0.25	4	155	50	¾"	7
EC20-180	0.58	6	176	55	¾"	9
EC20-200	0.83	9	200	65	¾"	13
EC25	1.2	12	230	75	1"	20
EC32	1.7	15	260	85	1¼"	26
EC40	2.7	20	280	90	1½"	31

Model	Max Flow Rate (l/sec)	Power (W)	Diameter (mm)	Depth (mm)	Connection Size	Weight (kg)
EC50	5	30	310	106	2"	42
EC65	8.3	35	365	120	2½"	61
EC80	10.8	40	420	125	3"	80
EC100	18.3	80	550	142	4"	157

1.4 Electrical Information

The unit does not produce stray currents.

Power supply input: 230V 1~ 50Hz

Power supply output to water conditioner: 12/24V dependent on model.

2. Water Conditioner Installation

2.1 Important: Health & Safety at Work Act 1974

Section 6(a) of this Act requires manufacturers to advise their customers on the safety and the handling precautions to be observed when installing, operating, maintaining and servicing their products. The user's attention is therefore drawn to the following:

- The appropriate sections of this manual must be read before working on the equipment.
- Installation, operating and maintenance must only be carried out by suitably trained/qualified personnel.
- Normal safety precautions must be taken and appropriate procedures observed to avoid accidents.

Refer to Dutypoint for any technical advice or product information. It is the responsibility of the customer and/or the contractor:

- To ensure that anyone working on the equipment is wearing all necessary protective gear/clothing;
- Is aware of appropriate health & safety warnings and to read the information in this manual.

2.2 Mechanical Device Servicing

- Familiarise yourself with the relevant contents of this manual
- Installation, maintenance and repair work must only be carried out by trained, skilled and suitably qualified personnel.
- Disconnect or lock-out the power source to ensure that the item(s) will remain inoperative. Locking out the equipment by switching off the release mechanism or set value WILL NOT prevent accidental starting.
- Allow the item(s) to cool if over-heated.
- CLOSE the isolating valves on the suction and discharge connections of the affected item(s).
- If working on pump, VENT slowly and cautiously – Refer to the relevant section of this manual.
- DRAIN the pump(s).

The unit should be installed before the plant heating equipment, either directly onto the system or by means of a bypass. Installation should be before boilers, heat exchangers and other heating equipment. The unit works most effectively with cold water. The unit should be sited after cold water storage tanks and typically after the cold water pump(s). Where the unit is supplied fitted to a Dutypoint booster set, this information is provided for reference purposes.

2.3 Standard Installation Procedure

- 1) If wall-mounted, the water conditioner can be installed in either the horizontal or vertical position.
- 2) Metal pipework can cause galvanic corrosion (also known as bimetallic corrosion). To prevent this, use dielectric unions or plastic pipe work.
- 3) Any mounting devices should be non-magnetic or separated from the unit with 50mm of insulating material
- 4) Install the power supply unit near the water conditioner (note the length of the cable).
- 5) Connect the cable coming from the water conditioner to the power supply socket in the bottom of the power supply unit.
- 6) Connect the power supply unit to the 230V mains with the cable and plug provided (a green LED on will indicate that the power supply is operating).
- 7) The orange LED in the power supply unit indicates the correct functioning of the water conditioner.
- 8) For integration with a BMS panel, the volt-free contact adapter provided should be fitted to a cable running from the BMS panel and plugged into the Volt-Free contact socket located on the bottom left of the power supply unit (see [2.5 Volt-Free Contact BMS Connection Wiring](#)). If the orange indicator goes off, (indicating the water conditioner is not functioning properly) a signal will be transmitted to the BMS panel.

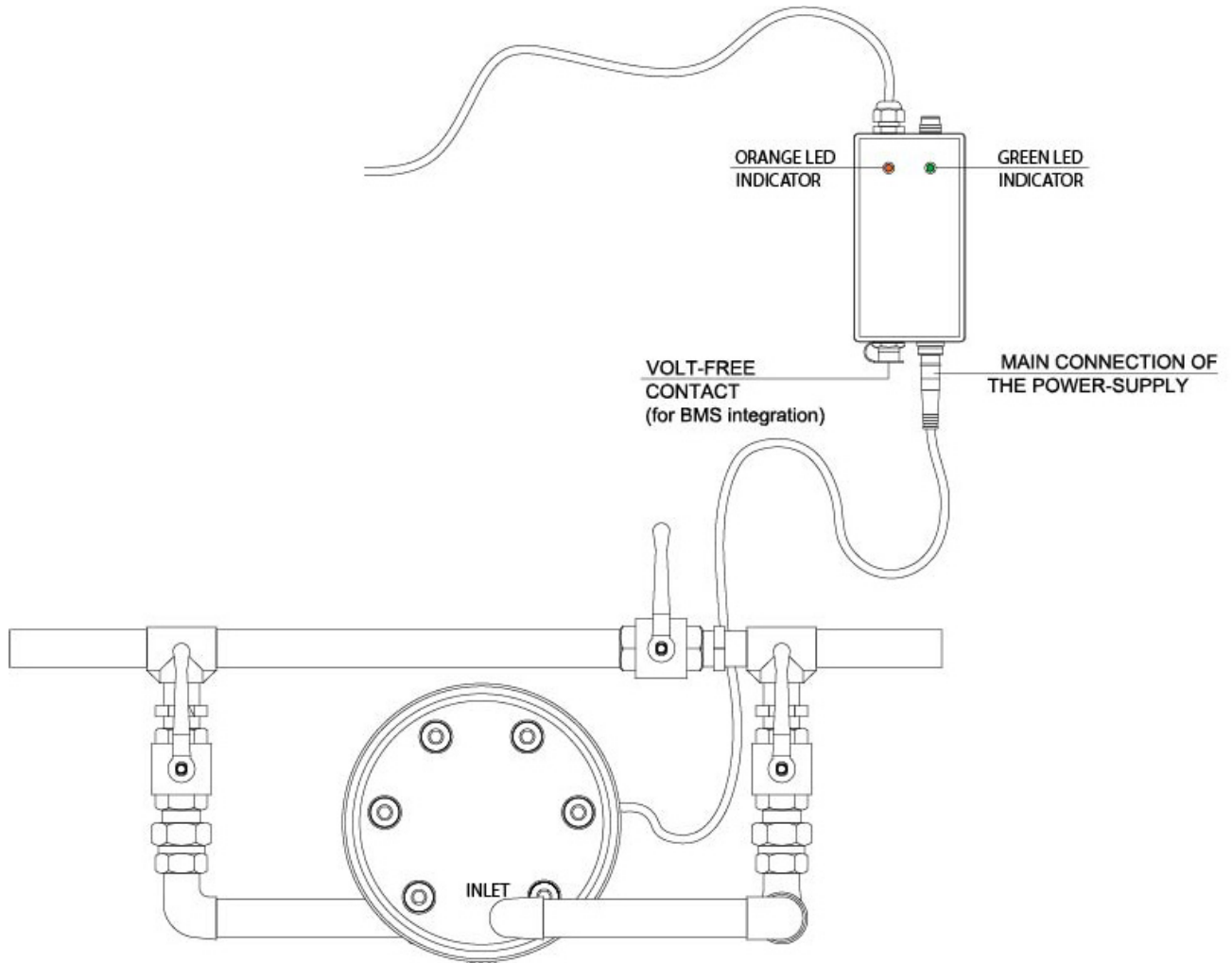
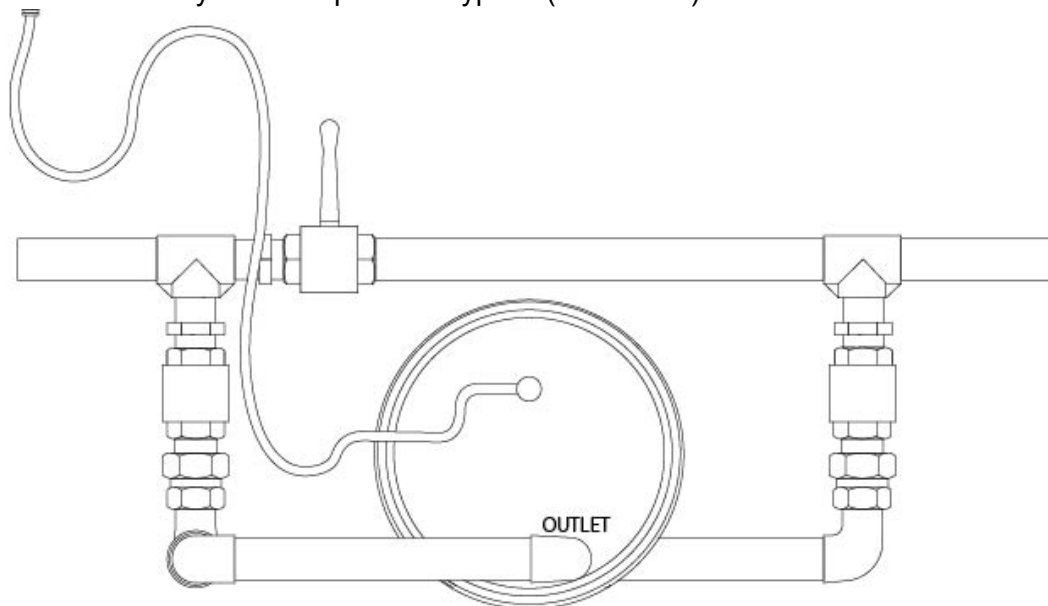
Figure 2.1: Installation Layout Example with Bypass (Front View)**Figure 2.2:** Installation Layout Example with Bypass (Rear View)

2.4 Skid Base Installation

If a metal skid base is specified on the order, the unit will be supplied ready installed as a single item on the skid base including pipework. The power supply unit will need connecting to the mains and the volt-free contact

connector (supplied separately - shown below) will need fitting to the end of the cable from the BMS panel. This connector should then be plugged into the BMS volt-free contact socket on the base of the power supply unit so that the water conditioner indicators will alert through to the BMS panel.) a signal will be transmitted to the BMS panel.

Figure 2.3: Metal Skid Base Installation Example

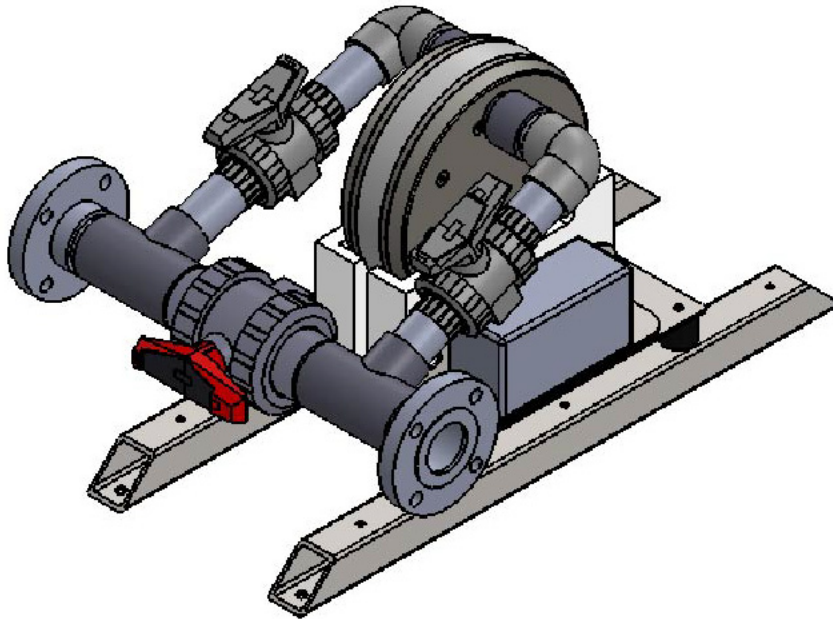

2.5 Volt-Free Contact BMS Connection Wiring

The unit's common fault volt-free contact is NC (normally closed), so is open in the event of a fault. The maximum current to be used on these terminals is 2A.

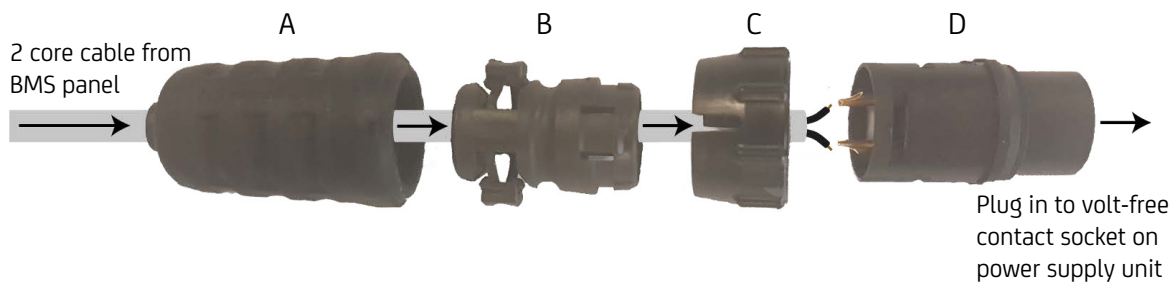

- 1) Feed 2 core cable from BMS panel through fittings A, B and C as shown above and wire cable cores into the back of connector piece D.
- 2) Push fitting B into the end of connector piece D. Fitting C should spin loosely over fitting D.
- 3) Plug connector piece D into the Volt-free contact socket on the power supply unit.
- 4) Screw fitting C up into place over the connection.
- 5) Pinching in the wings on fitting B and push the rubber sleeve fitting A up over all the other fittings to seal off the connection.

DUTYPOINT

PUMPS | SYSTEMS | SERVICING | KNOW-HOW

Dutypoint Limited
Shepherd Road
Gloucester
GL2 5EL
United Kingdom

T: +44(0)1452 300592
W: www.dutypoint.com