

DUTYPOINT

SETTING THE BAR

Dutypoint ResiSHIELD

Model - RZ

(for controller software versions V1.0f)



Operation and Maintenance Manual

DOC-RSRZ2312

DUTYPOINT

SETTING
THE BAR

About us.

Applied knowledge.
Shared know-how.
Fearless innovation.

Together, we are Dutypoint. Since 1976, we've been building up industry-defining expertise in fluid technology.

This knowledge means we solve complex challenges with straightforward solutions that are built around meeting and exceeding our clients' needs. We approach everything with the same philosophy: how will we go above and beyond?

Our commitment to collaboration and sharing knowledge galvanises and cements robust relationships. Relationships that are built to last, because our clients are our partners.

Our focus for the future? Innovation. We want to be the future of our industry, globally. Where we benchmark thought leadership, expertise and customer care.

We set the bar.

Contact details.

T: +44(0)1452 300592

E: info@dutypoint.com

Registered Office:

Dutypoint Limited
Quedgeley West Business Park
Bristol Road
Hardwicke
Gloucester
GL2 4PA
United Kingdom

Table of Contents

- 1. Important Safety Information 4
- 2. System Specifications 9
- 3. Control Panel Instructions..... 19
- 4. Installation and Commissioning.....31
- 5. Operation and Maintenance.....34
- 6. Troubleshooting 35
- 7. Wiring Diagrams36
- 8. Warranty..... 38
- 9. Declaration of Conformity.....39

1. Important Safety Information

1.1 Health & Safety at Work Act 1974

Section 6(a) of this Act requires manufacturers to advise their customers on the safety and the handling precautions to be observed when installing, operating, maintaining and servicing their products. The user's attention is therefore drawn to the following:

- The appropriate sections of this manual must be read before working on the equipment.
- Installation, operating and maintenance must only be carried out by suitably trained/qualified personnel.
- Normal safety precautions must be taken and appropriate procedures observed to avoid accidents.

Refer to Dutypoint for any technical advice or product information. It is the responsibility of the customer and/or the contractor:

- To ensure that anyone working on the equipment is wearing all necessary protective gear/clothing;
- Is aware of appropriate health & safety warnings and to read the information in this manual.

1.2 Safety Messages and Hazard Statement

Table 1.1: Hazard Notice Definitions

| Message Level | Definition |
|-------------------|-----------------------------------------------------------------------------------------------------------------|
| DANGER | A hazardous situation which, if not avoided, will result in death or serious injury |
| WARNING | A hazardous situation which, if not avoided, could result in death or serious injury |
| CAUTION | A hazardous situation which, if not avoided, could result in minor injury or moderate injury |
| ELECTRICAL HAZARD | Risks associated with electricity will cause hazards if not properly avoided |
| Note | A situation which may arise resulting in undesirable conditions and/or will not cause direct hazards to persons |

1.3 Qualified Personnel

WARNING

This product is intended for operation by qualified personnel only

- Only qualified personnel are allowed to install or operate this equipment
- Qualified personnel are defined as trained staff, who are authorised to install, commission and maintain equipment, systems and circuits in accordance with relevant laws and regulations. Personnel must be familiar with the instructions and safety procedures described in this document.
- This product should not be used by anyone with mental disabilities, or anyone without the relevant experience and knowledge, unless they have received instructions on using the equipment and on the associated risks, or are supervised by a responsible person.
- Children must be supervised to ensure they do not play on or around the equipment.

1.4 Environmental Protection

All local regulations and codes regarding emissions and waste disposal must be followed. This may include:

- Reporting of emissions to appropriate authorities

- Sorting, recycling and disposal of solid or liquid waste
- Clean-up of spills
- Separate disposal of electrical components from domestic waste

1.5 Mechanical Device Servicing

- Familiarise yourself with the relevant contents of this manual
- Installation, maintenance and repair work must only be carried out by trained, skilled and suitably qualified personnel.
- Disconnect or lock-out the power source to ensure that the item(s) will remain inoperative. Locking out the equipment by switching off the release mechanism or set value WILL NOT prevent accidental starting.
- Allow the item(s) to cool if over-heated.
- CLOSE the isolating valves on the suction and discharge connections of the affected item(s).
- If working on pump, VENT slowly and cautiously – Refer to the relevant section of this manual.
- DRAIN the pump(s).

1.6 Pump Hand Control Mode (Where Fitted)

In the 'HAND' position the pump(s) controlled by the switch will normally run at full speed and completely independently of any control devices, and can result in pump(s) running against a closed valve head if there is no draw. This can cause the system to be maintained at the maximum pressure produced by the pump plus any incoming pressure and additional pressure caused by water surge and can potentially damage the pump and other parts of the system.

The 'HAND' option should only be used with a competent operator in attendance, or when there is a continued demand sufficient to provide constant flow through the pumps to maintain the running pressure of the system to an acceptable level.

1.7 Personal Protective Equipment

Use personal safety equipment according to the site conditions and employer regulations. This may include, but may not be limited to:

- Hard hat
- Safety goggles with side shields
- Protective footwear
- Protective gloves
- Respirator
- Ear protection
- First aid kit
- Safety devices

1.8 Precautions Before Commencing Work

Ensure that the following safety precautions are complied with before commencing work:

- Create a safe working area, and provide a suitable barrier around the work area
- Ensure all safety guards are in place and secure
- Ensure you have a clear path of exit
- Ensure that the product cannot roll or fall over and cause damage to persons or property
- Ensure all lifting equipment is in good condition and rated for the intended task
- Use a lifting harness, safety line and respirator as required
- Allow hot components to cool before handling them
- Ensure that product has been thoroughly cleaned
- Disconnect and lock out power supply, ensuring that it cannot be accidentally re-connected

- Check for any risk of explosion before using hand tools

1.9 Precautions During Work

- Never work alone
- Always wear protective clothing and hand protection
- Stay clear of suspended loads
- Always use appropriate lifting devices
- Beware of risks of sudden starts of any automated equipment such as level control
- Beware of starting jerks of electric motors - these can be powerful
- Do not exceed the stated operating limits of equipment
- Do not remove vent plugs from a pressurised system - ensure pressurised components are relieved of pressure before disassembly
- Ensure guards are in place during operation

1.10 Hazardous Fluids and Chemicals

If hazardous chemicals come into contact with skin or eyes, use the following procedures:

| Condition | Action |
|---------------------------------------|-----------------------------------------------------------------------------------------------------------------------------------------------------------------------------------------------------------------------------|
| Chemicals or hazardous fluids in eyes | <ol style="list-style-type: none"> 1) Hold your eyelids apart forcibly with your fingers 2) Rinse the eyes with eyewash or running water for at least 15 minutes 3) Seek medical attention |
| Chemicals or hazardous fluids on skin | <ol style="list-style-type: none"> 1) Remove contaminated clothing 2) Wash the skin with soap and water for at least 1 minute 3) Seek medical attention |

1.11 Electrical Safety - High Voltages

This information is especially applicable when Variable Speed Controllers (Inverters) are fitted to pumps. When the inverter variable speed drive head is connected to the power supply the components of the power unit as well as certain components of the master control unit – are also connected to the power supply.

DANGER!

Touching these components can seriously endanger life!

- Before removing the frequency inverter cover, the system must be disconnected from the power supply
- After switching off the power supply wait at least 5 minutes before starting work on or in the inverter drive head - the capacitors in the intermediate circuit must be given time to discharge completely via the discharge restors.

ELECTRICAL HAZARD

Up to 800V can be present - if there are faults this can be higher

- All work carried out when the frequency inverter is open must be performed only by suitably qualified and properly authorised personnel.

ELECTRICAL HAZARD

THE SYSTEM MUST ONLY BE OPERATED WHEN IT HAS BEEN CORRECTLY EARTHED AND PIPES BONDED TO EARTH IN ACCORDANCE WITH IEE REGULATIONS

- When connecting external control wires care must be taken not to short circuit adjacent components. Bare cable ends which are not in use must be insulated.
-

1.12 Electronic Safety Devices

- Inverter drives contain electronic safety devices which switch off the control element in the event of a fault developing.
 - A motor can also be stopped by 'mechanical blocking'
 - If it is switched off electronically, the motor is disconnected from the mains voltage supply via the electronics in the inverter drive.
 - Voltage fluctuation and power failures (temporary outages) can cause the motor to switch itself off.
-

WARNING

A motor will have zero current but will remain energised as it stops

- Take necessary precautions - the motor is not voltage-free in the circuit itself
-

WARNING

Repair of faults can cause items to start up again unexpectedly

Ensure the motor is isolated before commencing any work

WARNING

High voltage tests of inverters may damage the electrical components.

- Bridge before the incoming/outgoing terminals L-L2-L3 and U-V-W.
 - To avoid incorrect metering by capacitors incorporated in the electronic circuits, isolate the motor from the inverter drive head.
-

1.13 Spare Parts

WARNING

Use of non-genuine spare parts may cause damage to equipment, damage to property and voiding of warranty

- Use genuine, Dutypoint-approved spare parts only
 - If in doubt, contact Dutypoint Service on 01452 300590.
-

1.14 Storage

The product must be stored in a covered and dry location free from heat, dirt and vibrations.

NOTE: Protect the product against humidity, heat sources and mechanical damage

NOTE: Do not place heavy weights on the packed product

1.15 Disposal

At the end of its working life, this product should not be disposed of with standard household waste, but rather dropped off at a collection point for the disposal of Waste Electrical and Electronic Equipment (WEEE) for recycling.

Figure 1.2: Waste Symbol



This is confirmed by the [Waste Symbol](#) found on the product, user manual or packaging.

Depending on their characteristics the materials may be recycled. Through recycling and other forms of processing Waste Electrical and Electronic Equipment, you can make a significant contribution towards helping to protect the environment.

Please contact your local authorities for information on the collection point nearest you.

2. System Specifications

2.1 Range Specifications

Table 2.1: Range Specifications

| Message Level | Definition |
|---------------------------|-------------------------------------------------------------------------------------------------------------------------|
| Application | BS9251:2021 Category 1 Fire Sprinkler Systems |
| Pumps | Dutypoint TH Horizontal Multistage. See p. 12 |
| Duty Flow Range | 30 - 450 l/min |
| Duty head range | 1 - 9.5 bar |
| Liquid temperature range | 1-23 °C |
| Ambient temperature range | 5 - 40 °C |
| Humidity | Max 50% |
| Controller Type | H500 (DOL) or H520 (soft start) series |
| Maximum System Pressure | 10 Bar |
| Volt Free Contacts | <ul style="list-style-type: none"> - Fire Mode Activated - Common Fault - Pump Running |

2.2 ResiSHIELD Range

Table 2.2: Product Identification

ResiSHIELD Range - Product Identification:

Example model number RZ0504E-MD-PL

RZ 0504E - M D - P L

Product Range

- DK Domestic Fire Pump Kits
- DH Domestic Fire Pump Sets
- RZ Residential Fire Pump Sets with Horizontal Pumps
- RV Residential Fire Pump Sets with Vertical Pumps

Pump Denomination

Supply Voltage

- M 230v 1ph 50hz
- T 415v 3ph 50hz

Starting Type

- D Direct On Line (H500)
- Y Star Delta (H510)
- S Soft Start (H520)
- V VFD (H530)

Pressure Control Type

- P System controlled via 2no pressure switches
- T system controlled via 1no pressure transducer and 1no pressure switch

Configuration

- L Suction connection located on left hand side of set
- R Suction connection located on right hand side of set

2.3 Product Overview

1. Controller
2. Water Suction Connection
3. Water Discharge Connection
4. Automatic Test Drain Connection
5. Pressure Gauge
6. Pump
7. Control Panel
8. Pressure Switch
9. Flow Switch
10. Non-Return Valve
11. Union
12. Isolation Valve
13. Manual Flow Test Valve
14. Auto Test Solenoid Valve
15. Primer Port

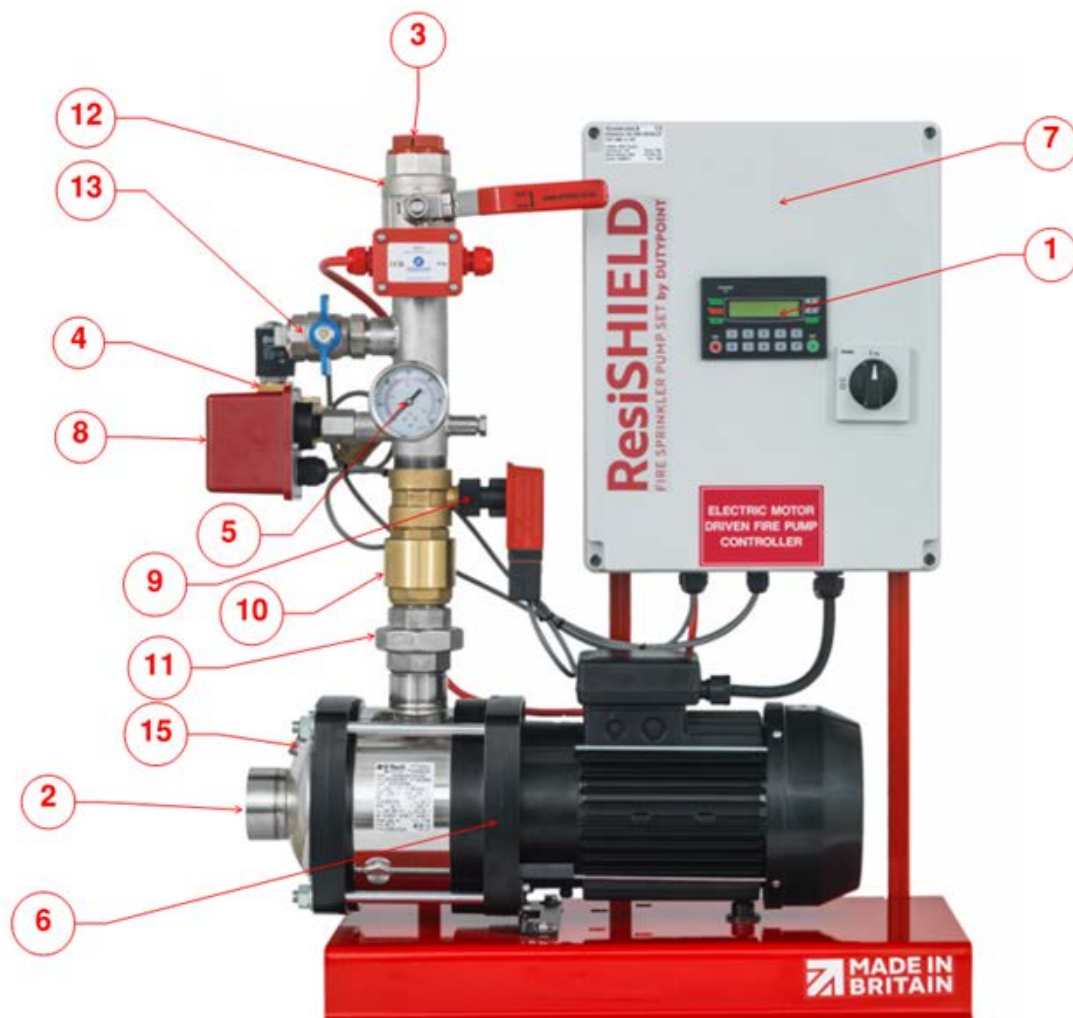

2.4 Technical Data

Table 2.3 : Range Matrix

| Model | Pump model | Supply Voltage | Motor Nominal Power (P2) kW | Motor Input Power (P1) kW | FLC (amps) | Suction Size (BSP) | Discharge Size (BSP) | Recommended Supply MCB Type |
|-----------|------------|----------------|-----------------------------|---------------------------|------------|--------------------|----------------------|-----------------------------|
| RZ0302E-M | TH3/2 | 230/1/50 | 0.33 | 0.46 | 2.5 | 1 1/4" | 1" | C6 |
| RZ0303E-M | TH3/3 | 230/1/50 | 0.45 | 0.6 | 3 | 1 1/4" | 1" | C6 |
| RZ0304E-M | TH3/4 | 230/1/50 | 0.55 | 0.76 | 3.7 | 1 1/4" | 1" | C6 |
| RZ0305E-M | TH3/5 | 230/1/50 | 0.75 | 0.91 | 4.3 | 1 1/4" | 1" | C10 |
| RZ0306E-M | TH3/6 | 230/1/50 | 0.9 | 1.13 | 5.4 | 1 1/4" | 1" | C10 |
| RZ0307E-M | TH3/7 | 230/1/50 | 1.1 | 1.28 | 6 | 1 1/4" | 1" | C10 |
| RZ0308E-M | TH3/8 | 230/1/50 | 1.3 | 1.43 | 6.9 | 1 1/4" | 1" | C10 |
| RZ0309E-M | TH3/9 | 230/1/50 | 1.5 | 1.58 | 7.5 | 1 1/4" | 1" | C16 |
| RZ0502E-M | TH5/2 | 230/1/50 | 0.45 | 0.59 | 3 | 1 1/4" | 1" | C6 |
| RZ0503E-M | TH5/3 | 230/1/50 | 0.55 | 0.81 | 3.9 | 1 1/4" | 1" | C6 |
| RZ0504E-M | TH5/4 | 230/1/50 | 0.9 | 1.1 | 5.3 | 1 1/4" | 1" | C10 |
| RZ0505E-M | TH5/5 | 230/1/50 | 1.1 | 1.32 | 6.2 | 1 1/4" | 1" | C10 |
| RZ0506E-M | TH5/6 | 230/1/50 | 1.3 | 1.53 | 7.3 | 1 1/4" | 1" | C16 |
| RZ0507E-M | TH5/7 | 230/1/50 | 1.5 | 1.74 | 8.2 | 1 1/4" | 1" | C16 |
| RZ0508E-M | TH5/8 | 230/1/50 | 1.85 | 2.4 | 10.5 | 1 1/4" | 1" | C16 |
| RZ0509E-T | TH5/9 | 400/3/50 | 2.2 | 2.29 | 4.3 | 1 1/4" | 1" | C10 |
| RZ1002E-M | TH9/02 | 230/1/50 | 0.75 | 0.87 | 4.3 | 1 1/2" | 1" | C10 |
| RZ1003E-M | TH9/03 | 230/1/50 | 1.1 | 1.24 | 6.3 | 1 1/2" | 1" | C10 |
| RZ1004E-M | TH9/04 | 230/1/50 | 1.5 | 1.7 | 8.2 | 1 1/2" | 1" | C16 |
| RZ1005E-T | TH9/05 | 400/3/50 | 2.2 | 2.2 | 4.1 | 1 1/2" | 1" | C10 |
| RZ1006E-T | TH9/06 | 400/3/50 | 2.2 | 2.61 | 4.7 | 1 1/2" | 1" | C10 |
| RZ1007E-T | TH9/07 | 400/3/50 | 3 | 3.08 | 5.5 | 1 1/2" | 1" | C10 |
| RZ1008E-T | TH9/08 | 400/3/50 | 3 | 3.49 | 6 | 1 1/2" | 1" | C10 |

2.4 Technical Data

Table 2.3 : Range Matrix

| Model | Pump model | Supply Voltage | Motor Nominal Power (P2) kW | Motor Input Power (P1) kW | FLC (amps) | Suction Size (BSP) | Discharge Size (BSP) | Recommended Supply MCB Type |
|-----------|------------|----------------|-----------------------------|---------------------------|------------|--------------------|----------------------|-----------------------------|
| RZ1502E-M | TH15/02 | 230/1/50 | 1.5 | 1.63 | 7.7 | 2" | 1 1/2" | C16 |
| RZ1503E-T | TH15/03 | 400/3/50 | 2.2 | 2.45 | 4.5 | 2" | 1 1/2" | C10 |
| RZ1504E-T | TH15/04 | 400/3/50 | 3 | 3.28 | 5.7 | 2" | 1 1/2" | C10 |
| RZ1505E-T | TH15/05 | 400/3/50 | 4 | 4.09 | 7 | 2" | 1 1/2" | C10 |
| RZ1506E-T | TH15/06 | 400/3/50 | 5.5 | 4.95 | 9.3 | 2" | 1 1/2" | C16 |
| RZ1507E-T | TH15/07 | 400/3/50 | 5.5 | 5.71 | 10.3 | 2" | 1 1/2" | C16 |
| RZ2002E-M | TH20/02 | 200/1/50 | 2.2 | 2.29 | 4.3 | 2" | 1 1/2" | C10 |
| RZ2003E-T | TH20/03 | 400/3/50 | 3 | 3.43 | 5.9 | 2" | 1 1/2" | C10 |
| RZ2004E-T | TH20/04 | 400/3/50 | 4 | 4.53 | 7.7 | 2" | 1 1/2" | C16 |
| RZ2005E-T | TH20/05 | 400/3/50 | 5.5 | 5.69 | 10.3 | 2" | 1 1/2" | C16 |

2.5 Pump Performance Curves

RZ03 Series

SINGLE PUMP CURVES

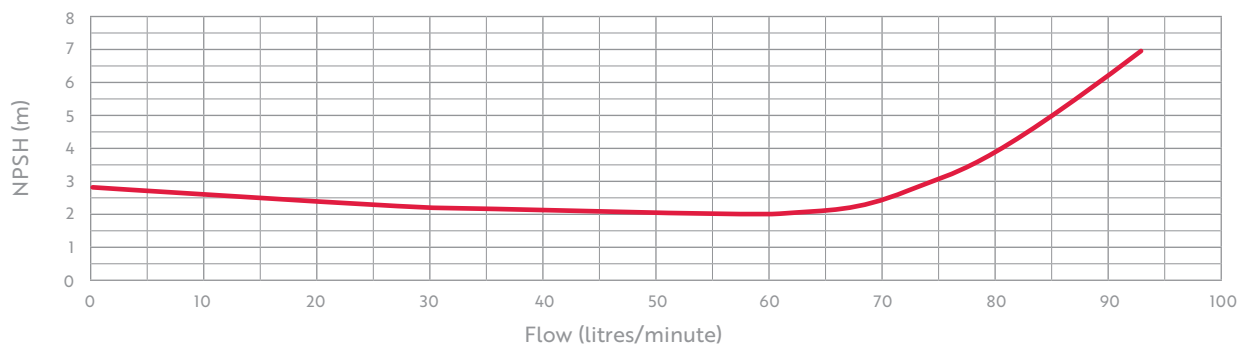
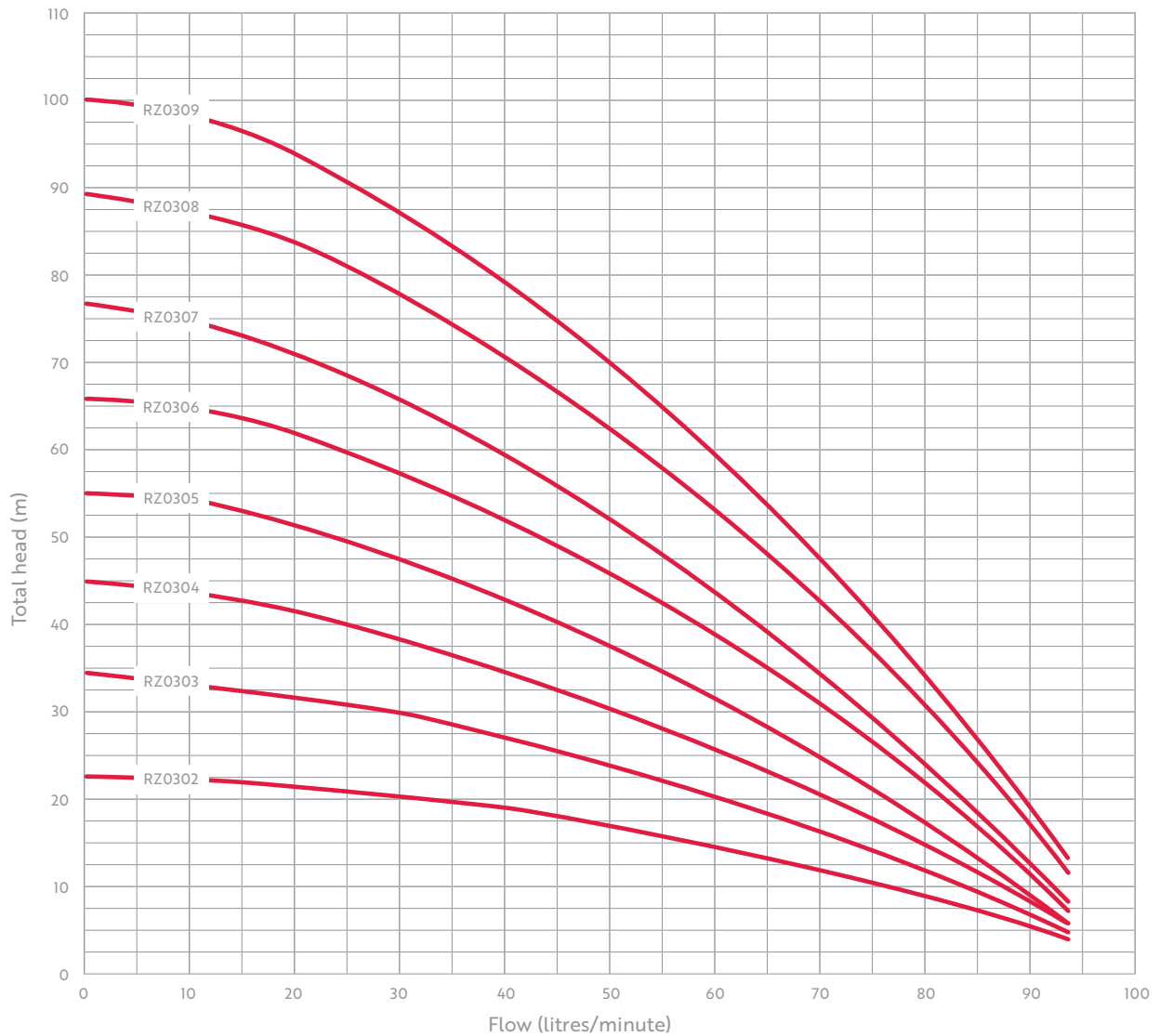

Pump performance curves continued

RZ05 Series

SINGLE PUMP CURVES

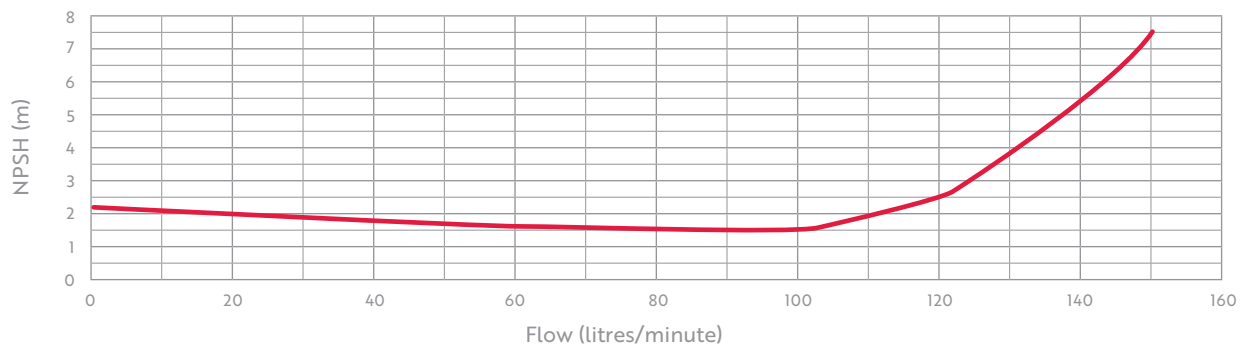
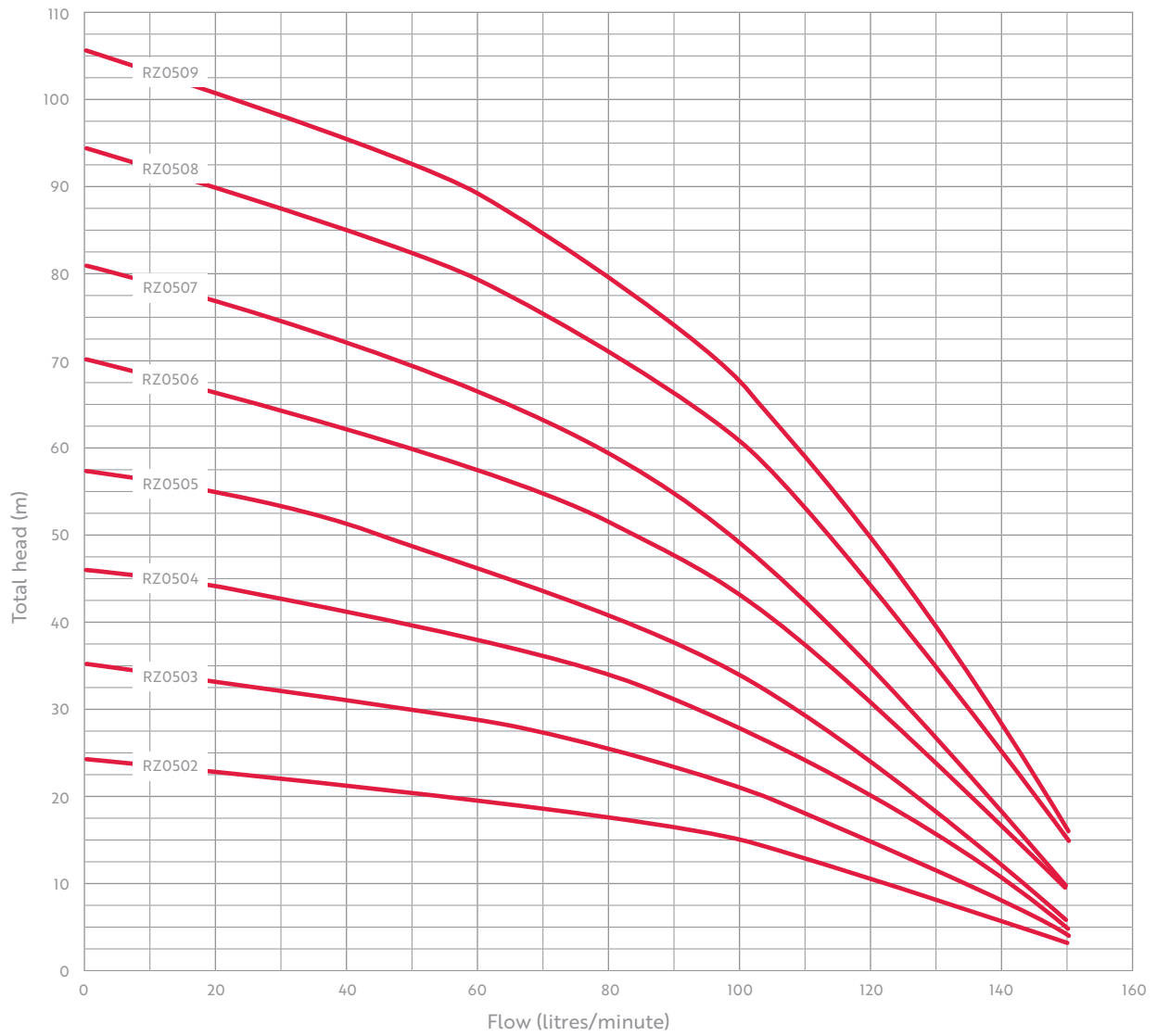

Pump performance curves continued

RZ10 Series

SINGLE PUMP CURVES

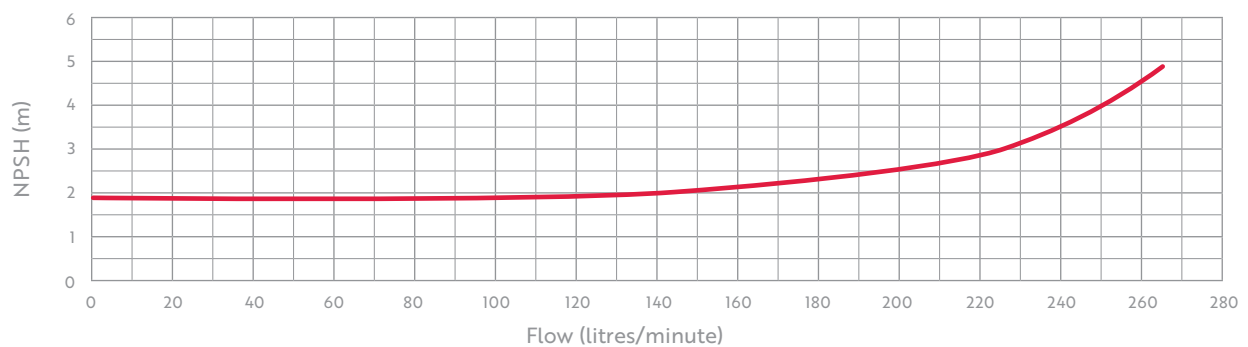
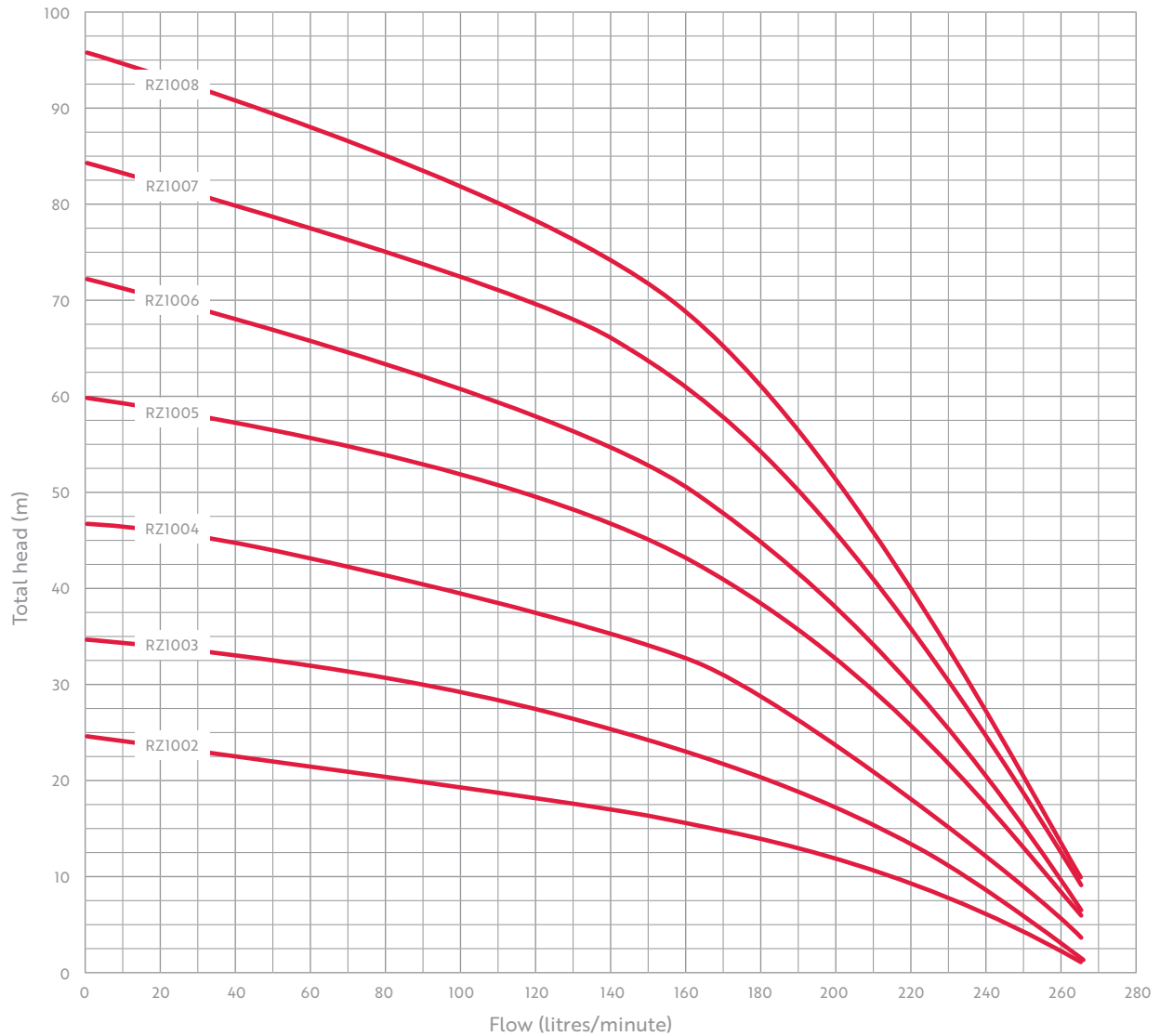

Pump performance curves continued

RZ15 Series

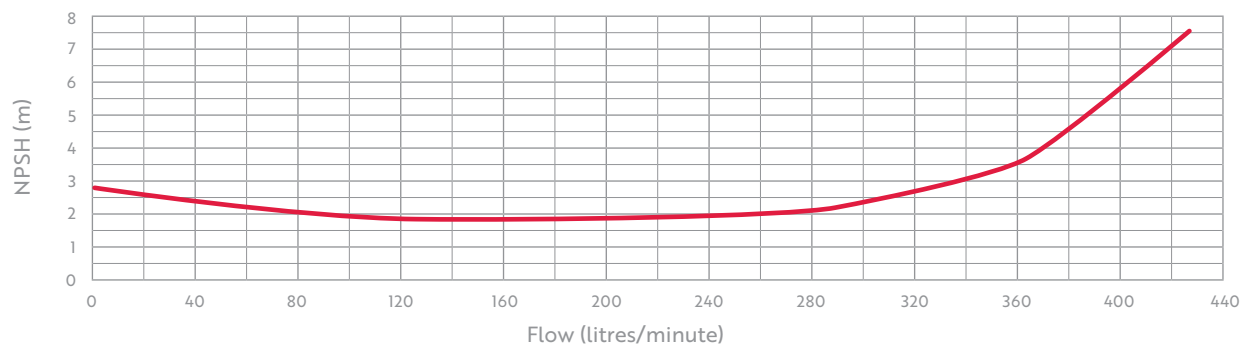
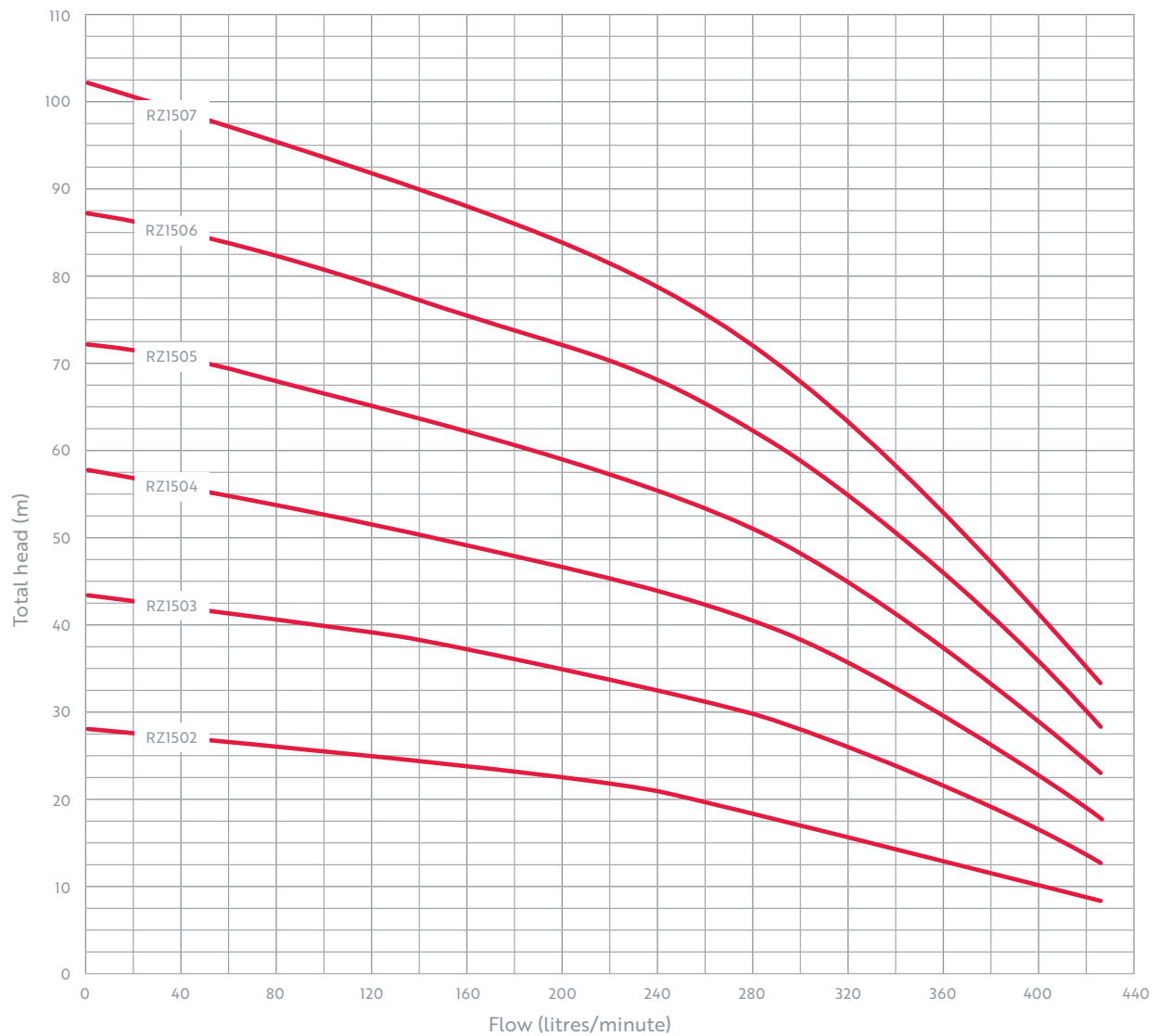
SINGLE PUMP CURVES

Pump performance curves continued

RZ20 Series

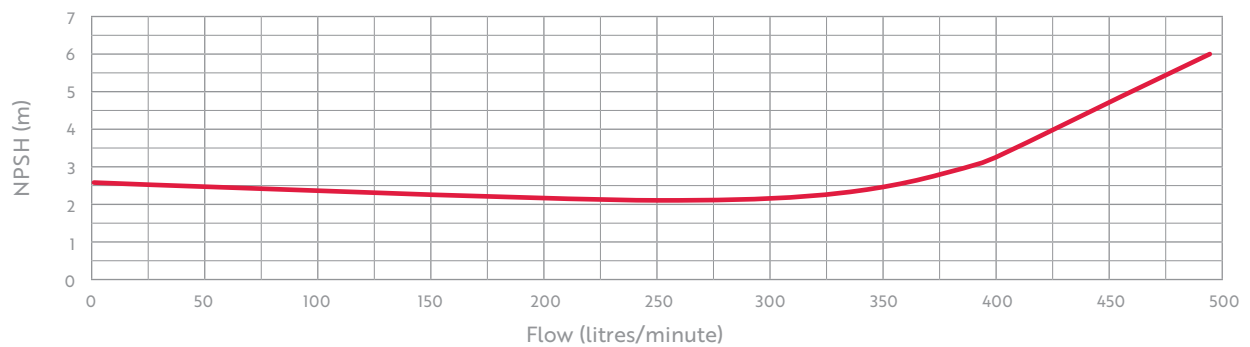
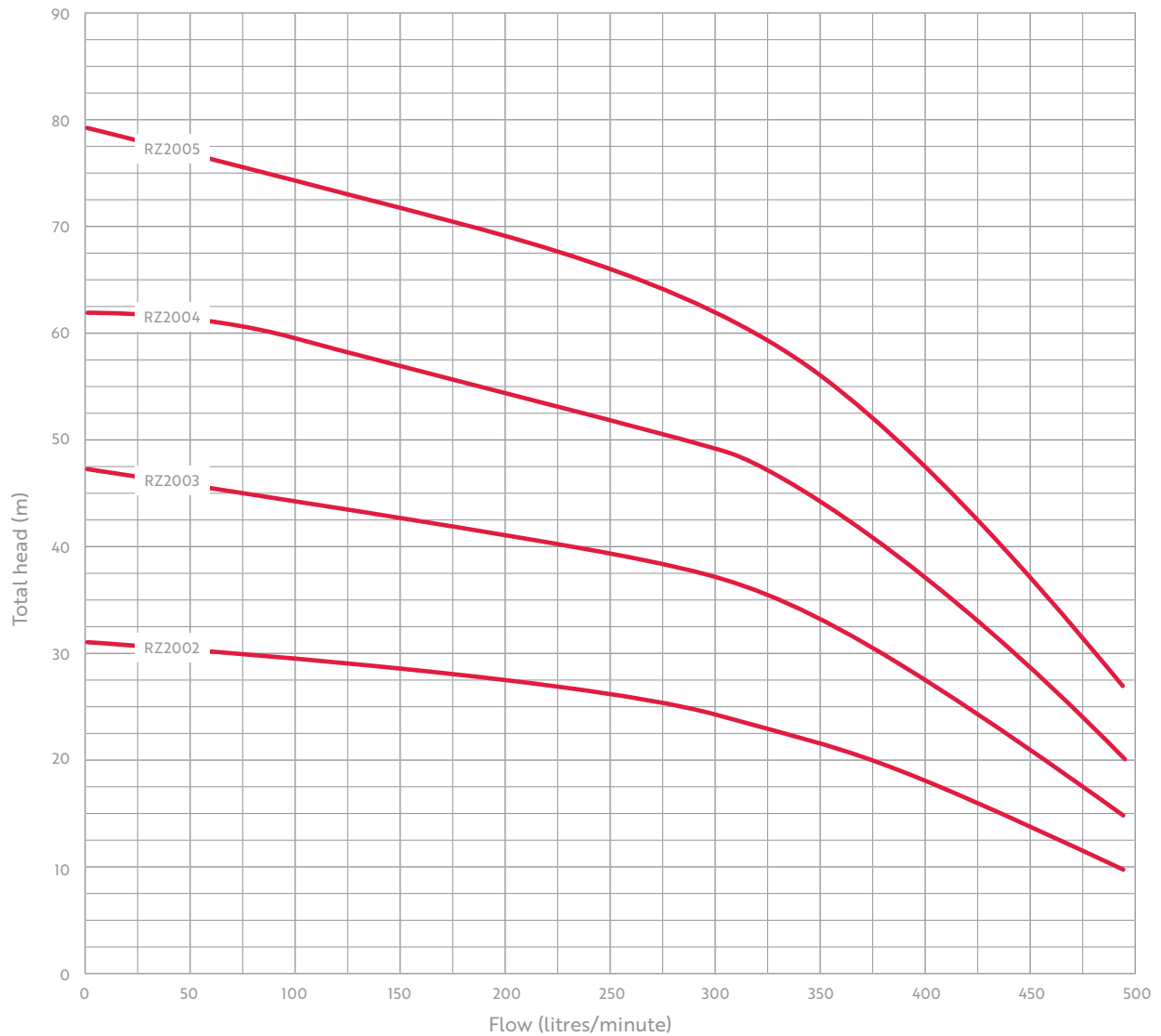
SINGLE PUMP CURVES

Operation Manual
Electric Motor Driven Residential Pump Controller
BS9251: 2021
Version 1.0f, May 2023
FOR FIRMWARE V1.0f
DIRECT ON LINE & SOFT STARTING

General

This controller is designed for the starting and stopping of one electric motor driven residential fire pump. The starting method is Direct on Line (H500) or Soft Start (H520). The controller is based around two electronic modules. One is the door mounted PLC (programmable logic controller) which is complete with an integral keyboard and a two line LCD (liquid crystal display), which is often referred to as an HMI (Human machine interface). The other electronic module is a purpose designed module by Dutypoint Ltd. This module is mounted on the gear tray and collects all the appropriate inputs signals and derives all the outputs at the correct voltage and power levels, this board also contains the power supply for the PLC. On this board there are various indicators to show the status of the controller and to aid fault finding.

Note: the module on the gear tray contains mains voltage. Before examining the fuses the mains supply should be fully isolated first.

Before the controller is operated for the first time, it is strongly suggested that the controller rating label is checked against the actual site conditions. For example, confirm that the site voltage matches the controller rating voltage and that the motor kW rating is the same as the controller.

If the controller is to be stored prior to installation, then it should be stored vertically in a dry place. Preferably it should be stored under cover in a dust free environment. If the controller is to be stored for greater than four weeks then action should be taken to avoid the build-up of moisture inside, such as a temporary anti-condensation heater.

When lifting the controller, the appropriate lifting equipment must be used. Before lifting ensure that the weight of the controller is well within the capabilities of the lifting equipment. The controller should be lifted by using appropriate slings, Lifting eyes and straps or lifting eyes if the controller has these fitted.

Every care has been taken during the design and testing stage to ensure that this controller will operate reliably within the intended environment. However, certain measures should be taken on site to help reduce installation issues. For example, all input signal cables should be installed in dedicated conduit, well away from noisy electrical and power / motor cabling.

The entirety of this manual should be read before the controller is first switched on. Please call Dutypoint Ltd for advice if you have any doubts regarding the suitability of this product for the intended installation or if you have any questions regarding the operation and function of this controller.

Switch on

Please be aware that when the controller is switched on, the pump could start immediately. It is suggested that the motor is disconnected until the settings and inputs are checked initially.

When the controller is first switched on, the following welcome screen is shown:

| | | | | | | | | | | | | | | | |
|--|---|---|---|---|---|---|---|---|---|---|---|---|---|---|---|
| | | < | H | a | r | r | i | j | e | s | s | > | | | |
| | H | 5 | 0 | 0 | | 2 | 0 | 2 | 1 | | V | 1 | . | 0 | D |

The bottom line shows the version number. Note that this manual is written only for a specific firmware version, and this should be verified, otherwise there could be differences in operation and set up.

Operation

When the system is healthy, the back light of the LCD will be green. When there is a fault, the back light is red. The LCD shows the system status of the controller, when the controller is in standby the following is shown: (Home page)

| | | | | | | | | | | | | | | | |
|---|---|---|--|---|---|---|---|--|---|---|---|---|---|---|---|
| P | S | 1 | | X | X | X | | | P | S | 2 | | Y | Y | Y |
| P | U | = | | A | A | A | A | | | | Z | Z | Z | | |

XXX = Pressure switch 1 status, either Off, On or Act

YYY = Pressure switch 2 status, either Off, On or Act

AAAA = Pump status, either stop or run or Sh Dn= Shutdown, due to low level
INH = start inhibited,

ZZZ = Pump started by; PSW= Pressure switch, FLOW=Flow switch, WST=Weekly test,
MAN=manual start pb & PS&F=Running due to flow switch being active while a pressure switch start was activated (minimum run timer timing) was closed*.

* The PS&F state will keep the pump running while the flow switch input is closed. It will stop as soon as flow ceases, or if that condition continues will latch into Fire mode.

Manual Start / Stop

To enter the manual mode, press the start p.b located on the left hand side of the screen when the motor is stopped, and the following screen will appear;

| | | | | | | | | | | | | | | | |
|---|---|---|--|---|---|---|---|--|---|---|---|---|---|---|---|
| P | S | 1 | | X | X | X | | | P | S | 2 | | Y | Y | Y |
| P | U | = | | A | A | A | A | | | | M | A | N | | |

To exit the manual mode, press the stop p.b at any time. No volt free contacts change state during this time.

Automatic Operation

The following screen depicts that the controller is in automatic mode and is ready to respond to the start inputs;

| | | | | | | | | | | | | | | | |
|---|---|---|--|---|---|---|---|--|---|---|---|--|---|---|---|
| P | S | 1 | | O | f | f | | | P | S | 2 | | O | F | f |
| P | U | = | | S | t | o | p | | | | | | | | |

Automatic start, Jockey Pump Mode

The controller is arranged with two pressure switch inputs, both are normally open, close to start. Both pressure switches can activate the start condition.

When there is a low pressure condition and no water flow:

| CAUSE / STATUS | EFFECT |
|-------------------------------------------------------|-------------------------------------------------|
| Water pressure begins to fall, Pressure switch closes | |
| Delay start timer times out (mode i) | |
| LCD | Relevant pressure switch shows "Act" |
| | Motor starts & runs |
| LCD | Pu= Run PSw (Running caused by pressure switch) |
| Water pressure rises, pressure switch open | |
| LCD | Relevant pressure switch shows "Off" |
| Minimum run timer operates (mode j) | |
| LCD | P=Stop |
| Time periods have elapsed | Motor stops |

Note: While the pump is running, the manual stop push button **can** be operated while the minimum run timer is operating with all of the pressure switch inputs open..

Water Flow

The controller has a water flow input, close to activate. When the water flow switch is closed, then it is assumed that there is a fire, and the pump will run continuously until manually stopped;

| CAUSE / STATUS | EFFECT |
|------------------------------------------------|----------------------------------------|
| Flow switch is activated | |
| Flow delay timer times out (mode k) | |
| LCD | Light=Red |
| | Motor starts & runs |
| Volt free contact | Fire activated |
| LCD | Pu-= Run Flow (Running caused by flow) |
| Pump will continue to run until manually reset | |
| When flow switch input has opened | |
| Press up arrow, until | Fsw=Act is shown |
| Press stop p.b | Motor stops |
| LCD | Green |

Water Flow Fault

The controller monitors the state of the flow switch continuously. If the pump runs for greater than 60s (mode x) because the water pressure is low, and the flow switch is not activated, then the controller will activate the flow fault condition. In this state;

| CAUSE / STATUS | EFFECT |
|--------------------------------------------------------------------------|------------------|
| After either pressure switch has been activated for >60s ((flow fault x) | |
| LCD | Light=Red |
| Volt free | Fire activated |
| LCD | Fsw=Er1 |
| Pump will continue to run until manually reset | |
| When relevant pressure switch input has opened | |
| Press up arrow, until | Fsw=Er1 is shown |
| Press stop p.b | Motor stops |
| LCD | Green |

If the pump restarts within the restart fault time (mode Z) Restart fault (default is 10s) time period, then the controller assumes that there is a fire condition and that the flow switch has failed. In this case, the pump will start and run until manually reset. To reset this fault, you must be on the page showing the flow switch fault (Fsw=Er2), and then press stop pb

| CAUSE / STATUS | EFFECT |
|------------------------------------------------------|--------------------------------------|
| Pumps stops | |
| Either pressure switch input closes | |
| LCD | Relevant pressure switch shows "Act" |
| This happens within Z;Restart fault time period, 10s | |
| Delay start timer times out | Motor will start |
| LCD | Flow switch fault, Fsw=Er2 |
| Volt free | Common fault |
| Stop p.b pressed | Motor is stopped if running |
| Volt free | Standby |

Test Start

The controller is fitted with a test start facility, this can either be manually or automatically activated. The manual test can be activated at any time by the test start p.b or via the automatically start.

The automatic start must be activated once a week. The day, hour and minute can be adjusted to suit the application and preference.

The purpose of the test run is verify both the pressure activation inputs and the pump output. When the test mode is activated, a drain valve is opened which simulates a drop in pressure and this action causes the motor to run. (Note; The motor will only start once both pressure switches are activated, this is

different to a normal start which will be activated by either pressures switch). When the pump runs, the pressure activation inputs will clear and the motor will stop after a time delay.

The test mode is cancelled if any of the following events occur;

Flow switch activates Stop p.b is pressed Low water level Pressure not restored

Normal Sequence, when the test start is activated the following occurs:

| CAUSE / STATUS | EFFECT |
|-----------------------------------------|------------------------------------------------------|
| Test start activated | Drain valve opens & water pressure will fall |
| Pressure switches indicate low pressure | LCD shows low pressure value |
| LCD | Shows test mode = on "WSt" |
| Controller starts motor | Pump starts producing pressure Drain valve closes |
| Pressure rises above stop pressure | Pressure switches both clear |
| Motor & pump run for test run period. | Motor & pump is stopped |
| LCD | Shows test mode = off |
| Standby | |

Pressure Sensing Devices do not operate, when the test start is activated the following occurs:

| CAUSE / STATUS | EFFECT |
|----------------------------------------|---------------------------------------------------------------------------------------------------------------|
| Test start activated | Drain valve opens & water pressure will fall |
| Pressure sensing device do not operate | |
| After 10s | |
| LCD | Test start error – LCD background = red WST= "DV Err" if neither operate or "PS Err" if only one operates. |
| Volt free | Common fault |
| Stop p.b pressed by operator | Fault clears – LCD background = green |
| Standby | |

Pressure does not restore when drain valve closes, when the test start is activated the following occurs:

| CAUSE / STATUS | EFFECT |
|-----------------------------------------------------------------|-----------------------------------------------------|
| Test start activated | Drain valve opens & water pressure will fall |
| Pressure transducer and pressure switch indicate low pressure | LCD shows low pressure value, Drain valve closes |
| Controller starts motor | Pump starts producing pressure |
| Pressure does not rise | |
| After a time delay | Test mode is cancelled |
| LCD | Test mode is off |
| Pump will continue to run until the start commands are cleared. | |

Excessive Starts

The controller records each start of the pump over a 7 day period. If the total number of starts exceeds the set point (O) then an alarm is raised. The pump will continue to operate as normal in this state.

To clear this fault, you must be on the page showing the excessive starts fault (>Sta=On) then press the stop push, this will clear all excessive start logs for the entire week.

Manual starts and weekly / manual tests are not counted.

| CAUSE / STATUS | EFFECT |
|-------------------------|--------------------------------------------------------------------|
| Pump starts by any mode | Logged number of starts for last 7 days exceeds set point (Mode O) |
| LCD | >Sta=Err, LCD background = red |
| Volt free | Common Fault |

Autostart Inhibited

The controller is equipped with an autostart inhibit input, x6. This is wired directly to the back of the PLC. When this input is closed, the following starts are inhibited;

- Pressure switch 1 or 2
- Restart due to low pressure
- Flow switch
- Test start (manual or automatic)

The screen will show "INH" on the home screen for pump status. The screen remains green, and the common fault is NOT activated.

Manual start is still available when inhibited.

This input is intended for dual pumping sets when only one pump can run at any one time.

Set Points & Status Information

By using the up and down arrows the user can scroll through various user adjustable set points and status information:

| Parameter | Description | | | | | | | | | | | | | | | | |
|-------------------------|-----------------------------------------------------------------------------------------------------------------------------------------------------------------------------------------------------------------------------------------------------------------------------------------------------------------------------------------------------------------------------------------------------------------------------------------------------------------------------------------------------------------------------------------------------------------------------|---|---|---|---|---|-----|---|---|---|---|---|---|---|---|---|-----|
| a; Hours run | Indicates how long the pump has been running for, in hours, minutes and seconds. | | | | | | | | | | | | | | | | |
| b; Number of starts | Shows the number of times that the pump has started. This number includes both manual, test and automatic start. | | | | | | | | | | | | | | | | |
| Daily number of starts | Shows the number of daily starts over the last week. These number of starts get reset each day at midnight. Example screen; <table border="1" data-bbox="576 683 1374 757"> <tbody> <tr> <td>S</td> <td>2</td> <td>M</td> <td>3</td> <td>T</td> <td>4</td> <td>W</td> <td>5</td> </tr> <tr> <td>T</td> <td>6</td> <td>F</td> <td>7</td> <td>S</td> <td>1</td> <td>=</td> <td>2 8</td> </tr> </tbody> </table> <p>This shows; Sunday =2, Monday=3, Tuesday=4, Wednesday=5 Thursday=6, Friday=7, Saturday=1 and the total number of starts during the last week is 28.</p> | S | 2 | M | 3 | T | 4 | W | 5 | T | 6 | F | 7 | S | 1 | = | 2 8 |
| S | 2 | M | 3 | T | 4 | W | 5 | | | | | | | | | | |
| T | 6 | F | 7 | S | 1 | = | 2 8 | | | | | | | | | | |
| f; Real time clock | This screen shows the internal real time clock value. This is only used to activate the test run. To adjust the real time clock, no password is required, then press Enter and 1 to increment hours Enter and 6 to decrement hours Enter and 3 to increment minutes Enter and 8 to decrement minutes Enter and 4 to increment days Enter and 9 to decrement days | | | | | | | | | | | | | | | | |
| g; Weekly start setting | This shows the hours, minutes and day the weekly test start. This is adjusted using the same keys as for the real time clock. Set the day to "Off" to disable the automatic weekly test. | | | | | | | | | | | | | | | | |
| h; Security Code | To gain access to the engineers settings, the correct security code must be entered. | | | | | | | | | | | | | | | | |

Notes on the PLC & HMI.

All of the user set points are stored in non-volatile memory. The non-volatile memory is able to keep the set points for over 5 years without power. The system also has an internal battery to help maintain the settings.

When the security code has been correctly entered, the user has 2 minutes before this is automatically cancelled and the screen is returned to home.

If the security code is not set, and the user leaves the display not in the home screen, then after 1 minute the display will automatically revert back to the home page.

By pressing the esc key at any time for >0.5s will make the screen revert back to the home page.

Firmware History

Ver 1.0 = Initial. December 2021

Ver 1.0b= December 2022, rewritten for two pressure switches and alternative PLC.

Both pressure switches and delay start timer active before flow switch fault is active. Previously it was just a pump running condition in jockey pump mode for time period. "Er1 is activated"

If pump restarts within z;restart fault time period then flow switch fault "Er2" is activated and pump runs at full speed.

Ver 1.0c= Start inhibited added from input x6, and 1/3 phase selection added

Ver 1.0d= Common fault volt free no longer trips in fire mode
If one pressure switch failure during test, screen show PS Err instead of just Error
Spare output configuration added
Fixed WST minutes so it can be set to 0.
If pressure start & flow switch closed, pump continues to run while flow switch is closed.
Stop p.b now inactive while in fire mode and flow switch is closed
In fire mode due to pressure switch or restart fault, with no flow, drain valve will open briefly (mode 2) for a set time (mode 1)

Ver 1.0f= Load default values, when the security code is entered, now 4 digits not 2.
Test start, now waits for both pressure switches to activate before motor is started. A
Test start no longer waits for the delay start timer.
24 hour mute facility added, via test p.b. Indicator on test p.b is lit if alarm is muted
Indicator on test p.b is lit while in test mode
If Test run time is lower than test cancel, not operated time then the system does not detect a pressure switch fault during the test. So an error is now shown on the setting screen if these parameters are mis-set.

Cause and Effect Chart

| Condition | LCD | Common Fault v/f | Fire mode activated v/f | Shuts down Pump | Reset | Starts Pump | Comment |
|--------------------------------------|-----------------------|------------------|-------------------------|-----------------|------------|-------------|------------------------------------------------------|
| AC Mains failure | AC=ERR | Yes | No | No | Auto | No | |
| Low Tank Level | Tank=Err | Yes | No | Optional | Auto | No | |
| Pressure switch start | PS=Act | No | No | After min run | Auto | Yes | |
| Flow Switch activated | FLOW FSw= Act | Yes | Yes | No | Stop p.b | Yes | Runs until stop p.b is pressed & flow switch is open |
| Excessive starts | >ST= On | Yes | No | No | Stop p.b | No | |
| Low pressure for x:Flow fault time | FSw=Er1 | Yes | No | No | Stop p.b | Yes | Flow switch fault Runs until stop p.b is pressed |
| Restarts within z:restart fault time | FSw=Er2 | Yes | No | No | Stop p.b | Yes | Runs until stop p.b is pressed |
| | | | | | | | |
| Test Start Related | | | | | | | |
| Test start | WST=Run | No | No | No | Stop p.b * | Yes | Starts via drain valve |
| Drain valve does no open | DV=Err | Yes | No | No | Stop p.b * | No | |
| Pressure switch does not activate | PSw=PS Err WST=Err | Yes | No | No | Stop p.b * | No | |
| Pressure remains low during test | WST=Off | Yes | No | No | Stop p.b * | No | Runs until stop p.b is pressed |

P.Switch / P.Sw= Pressure Switch, FSw = Flow switch, WST= Weekly start test, DV=Drain valve, Err=Error
 Stop p.b * = Stop p.b must be pressed on the screen showing the actual error

Service Engineer Settings; Enter 77 into the security code to access;

| Parameter (default value) | Description |
|----------------------------------|---------------------------------------------------------------------------------------------------------------------------------------------------------------------------------------------------------------------------------------------------------------------------------------------------------------------------------------------------------------------------------------------------------------------------------------------------------------------------------------------------------------------------------------------------------------|
| i; Delay start timer (1s) | Adjustable from 1-250 seconds. This timer is intended for multiple pump installations, so that the lag pump is only started if the lead pump cannot make the required water pressure. For example, both pumps are set to the same start pressure, then the lead pump is set to 1s delay start, and the lag pump is set to say 10s. When the pressure drops, the lead pump starts immediately, the lag pumps gives the lead pump 10s to clear the demand. If the water pressure rises above the reset pressure within 10s then the lag pump will not start. |
| j; Min run time (5s) | Adjustable from 0-600 seconds. Default 5s. This timer starts to time when the motor has started. When this timer has counted down to zero, AND if there is no pump on demand, then the motor will automatically stop. |
| k; Flow delay (30s) | Adjustable from 0 to 30s. The time delay is the amount of time that must expire between the flow switch input closing and the pump start. The purpose of the timer is to mask out any brief periods of water flow during the jockey pump function of the controller. If set to 0, then the flow switch features are disabled. E.G no flow switch fault if pressure run is >60s |
| p; Tank Low stop (1) | This can be set to yes or no. Yes= motor will be shutdown when tank level low is activate No= Pump will NOT be shutdown when tank level low is activated |
| q; Excess starts (14) | If the number of starts in 1 week exceeds this value then the excessive starts ">St" alarm will be raised. |
| Test cancel, not operated (5s) | This is the amount of time allowed for both pressure actuation devises to respond after the drain valve is opened. Alarm is raised and test mode cancelled. |
| Test cancel, low pressure (6s) | This is the amount of time, in seconds, the system allows for the pressure to build up again after the drain valve closes. If this time is exceeded then the test mode is cancelled. |
| w; Test run time (20s) | This is the amount of time the pump will run during a test start, in seconds. NOTE; this value must be above the "Test cancel, not operated" value otherwise a message "ERR, INC" will be shown, which means error, increase the value. |
| x; Flow fault (10s) | This the flow switch fault timer, in seconds. If the pump runs due to a low pressure condition, with the flow switch not activated, then after this amount of time the controller will activate the flow switch fault condition. |
| y; Restart fault (5s) | If the pump restarts within this time period then a flow switch fault is declared and the pump will run until manually reset. Default is 10s |
| Z; Three phase | Select yes for a 3 phase supply, 0 for single phase |

| | |
|-------------------------------------------------------------------|--------------------------------------------------------------------------------------------------------------------------------------------------------------------------------------------------------------------------------------------------------------------------------|
| 1; Trip no flow DV close time Set to 0 to disable | When latched in fire mode due to pressure switch being closed for too long, or due to restart fault, with no flow, the system allows the drain valve to open periodically. This sets the time between the valve opening. |
| 2; Trip no flow DV open time In seconds Set to 0 to disable | When latched in fire mode due to pressure switch being closed for too long, or due to restart fault, with no flow, the system allows the drain valve to open periodically. This sets the time between the valve opening. This sets the amount of time the drain valve is open. |
| 3; Output RL3 | This sets for the function for the spare volt free contact RL3; 1= In test or pump running 2= AC Healthy 3=Low water level OR in fire mode 4= Alarm activated |
| 4; Output Y5 | This sets for the function for the spare output Y5; 1= In test or pump running 2= AC Healthy 3=Low water level OR in fire mode 4= Alarm activated |

Note; The alarm activated output, if used, can be muted by pressing the mute (auto) push button. Once muted the indicator next to the mute (auto) push button is lit. The alarm will remain muted for 24 hours, if the alarm is deactivated it will automatically clear.

4. Installation and Commissioning

4.1 Installation and Commissioning Overview

Please give careful consideration to the following prior to commencing the installation:

- The system should be positioned such that the controller screen can be easily seen.
- Adequate clearance should be provided to enable removal of cover and access to all the components within.
- Protection should be provided against frost and rain.
- The suction and discharge pipework must be at least of equal size to that of the corresponding ResiSHIELD pipe connection sizes
- All electrical connections should be carried out by a qualified electrician.
- All mechanical connections should be carried out by a qualified and authorised professional in accordance with BS9251 latest revision and relevant codes of practice.
- The unit must not be switched on under any circumstances until the system has been filled with water and primed.

4.2 Mechanical Installation

Recommended pipework arrangement:

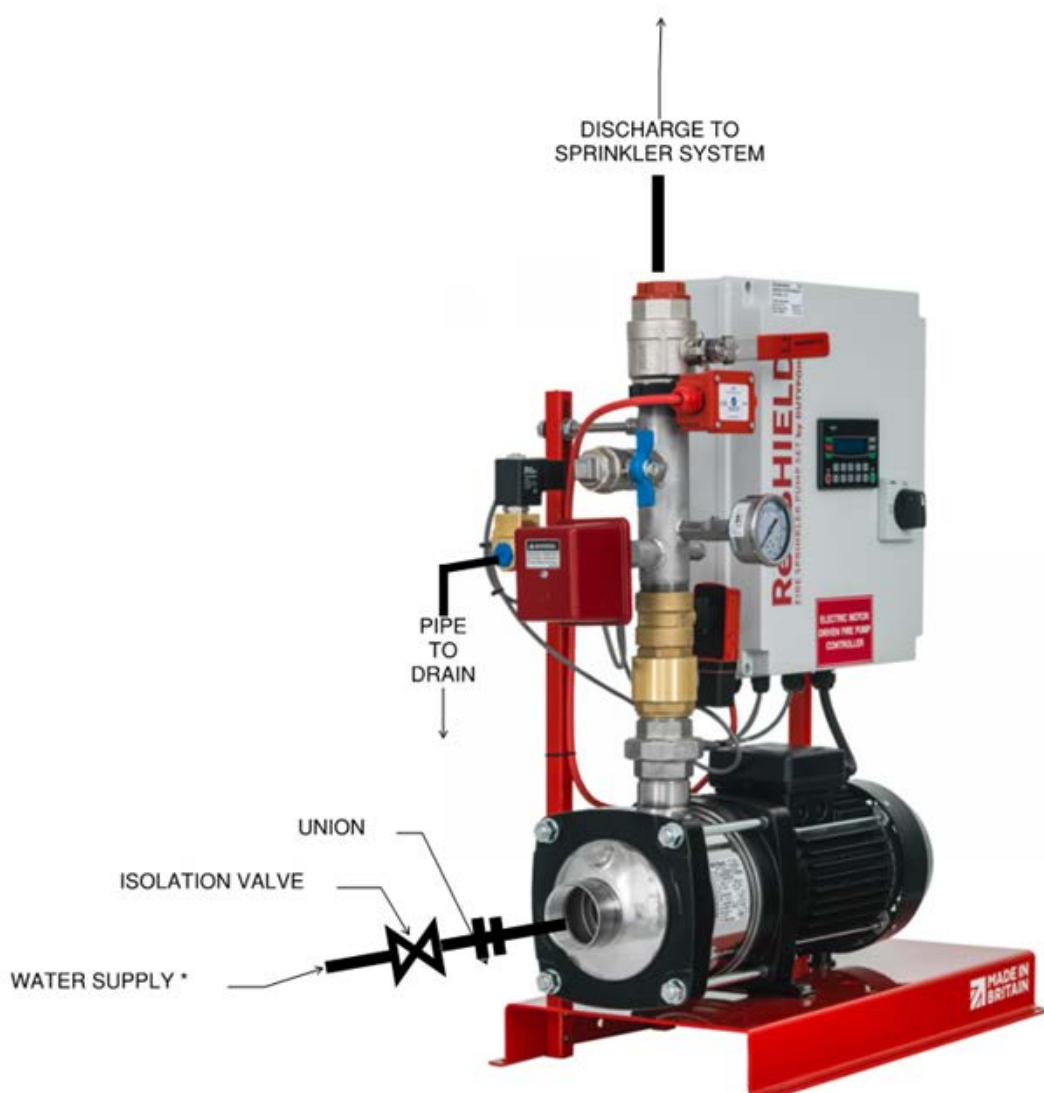

4.3 Electrical Installation

- 1) Please give careful consideration to the following instructions:
 - a) All electrical connections should be carried out by a qualified electrician
 - b) The pump set should be supplied on a dedicated, MCB protected circuit. Please refer to page 12 for MCB type information according to the specific model.
 - c) The ResiSHIELD RZ is supplied with a 1.5m length of power supply cable pre-wired into the control panel. It is recommended that this is terminated into a nearby isolator switch to enable convenient isolation for future maintenance and repair.
 - d) Where a UPS or Generator supply is to be used, consideration must be made for the starting current of the pump.
 - e) For DOL panels (H500), the starting current is 6x the FLC
 - f) For Soft-Start panels (H520), the starting current is 3x the FLC
 - g) Please refer to page 12 or 13 for FLC rating information for your specific model.

4.4 Low Level Float Switch Wiring

The ResiSHIELD RZ has provision to connect an optional low tank level switch (terminals 6.1 & 6.2 - refer to wiring schematics on page 31).

When the low level float switch is activated, a fault will show on the LCD by way of the screen backlight turning red, and the tank status window will show message 'Tank=Err'. In the event of tank level rising back up to normal level, the fault alarm will automatically reset.

The system can be set to either inhibit the pumps or not in event of low water level (see 'Tank low stop' parameter).

4.5 Monitoring and Alarm Signals

The ResiSHIELD RZ includes the following volt free contact outputs:

| Description | Terminals | | | Triggered by |
|--------------------------|----------------|---------|----------------|----------------------------------------------------------------------------------------------------------------------------------|
| | Common | NC | NO | |
| Fire Mode Activated | PLC4.9 | PLC4.10 | PLC4.8 | Flow switch being active for <30s |
| Pump running | 13 (contactor) | N/A | 14 (contactor) | Pump contactor closing |
| Common Fault | PLC4.3 | PLC4.4 | PLC4.2 | - Nuisance Cycling (excess starts per week) - Automatic weekly test failure - Flow switch fault - Pressure Switch Fault |
| Discharge Valve Position | 1 | 2 | N/A | - valve moving away from fully open position |

4.6 Venting the Pump

It is important to bleed all air from the pump body before initial start up. This can be done by loosening the venting port at the top of the pump body, let the air out until water starts coming out, then re-tighten.

4.7 Final Checks before Commissioning

The skid plate is securely fixed to the floor using the fixing holes provided.

Suction pipework installation is complete and pressure tested.

Discharge pipework installation including full sprinkler system is complete and pressure tested.

Drain pipework from the auto test drain point is complete.

Electrical connection has been completed including installation of an isolator switch within arms reach of the ResiSHIELD.

The MCB used to supply the ResiSHIELD matches the recommended rating on page 12 & 13.

Control signal cabling has been completed as required (ref section 4.5)

4.8 Commissioning Procedure

ResiSHIELD RZ pump set pressure switches are factory configured to the project requirements according to the information provided by the client. However, the pressure set point may need fine tuning once in situ. It is the sprinkler contractors responsibility to double check and ensure that the ResiSHIELD is set to the correct pressure set point according to their as-built system requirements in accordance with BS9251:2021.

The pressure switch set point to which the unit has been set to in the factory is printed on the data label. If the set point needs to be adjusted, this must only be carried out by an authorised, competent, qualified person, and the new set point must be labelled below the main data label.

1. Ensure that all points in the previous section 4.7 have been checked.
2. Close the isolation valve on the discharge of the system. Open the isolation valve on the suction side of the system. Check the pump is fully primed by loosening the priming screw on the pump until water comes out, then re-tighten.
3. Open the discharge isolation valve and fill / prime the whole system as necessary. Check and rectify any leaks.
4. Turn the power supply on. If the system pressure is below set point, the pump will run for a minimum of 5 seconds and pressurise the system. Once the pump has successfully created and maintained duty pressure in the system and surpassed the 5 second minimum run time, it will then stop. The LCD backlight will turn green once the system status is normal.
5. Tune the pressure switch set point against the pressure gauge according to the system requirements.
6. Check automatic test functionality by pressing the 'test' button. This will run the weekly test procedure to check pump and pressure devices, and the pump will run for a minimum of 20 seconds. Check that there are no errors (indicated by a red screen) following completion of the test.
7. Test fire mode by creating flow through the manual flow test port. Fully open the test port valve to create significant flow through the system. After 30 seconds, close the valve again. The pump should continue to run even after pressure is restored, until the 'stop' button is pressed.
8. If the fire signal from the ResiSHIELD is being used, check that the fire signal was received during the flow test.

5. Operation and Maintenance

5.1 User Operation

- The ResiSHIELD is designed to operate automatically and therefore requires minimal user input.
- Routine visual check of the controller screen is required. If the backlight is Green, everything is ok. If it is Red, there is a fault. In event of fault, the user can use the up and down arrows to scroll through the system status pages to check where the fault is. Please refer to section 3 for full details on the various information available through the screen. When the controller is showing the screen which the fault is highlighted, pressing the stop button will reset the fault. Intervention on the cause of the fault must be taken.
- Following a fire event where the sprinkler system has activated and confirmation that the fire is out, the ResiSHIELD unit can be stopped if the pressure is restored to the set point by pressing the stop button.

5.2 User Inspection

The ResiSHIELD should be inspected at regular intervals of not more than 3 months to ensure correct operation of the unit between service visits. This inspection should include the following:

1. Check the controller LCD is green, ie status normal.
2. Check the system pressure on the gauge is at or above the pressure set point of the system.
3. Check the general pipework and fittings for any signs of leaks, corrosion or damage.

5.3 Maintenance & Servicing

1. There are no user servicable parts in the ResiSHIELD unit.
2. Servicing of the complete fire sprinkler system including the ResiSHIELD should be carried out by suitably qualified personnel at least annually as recommended by BS9251:2021.
3. The record of any service visits should be added to the history log at the back of this manual.
4. Should maintenance be required on mechanical components with the ResiSHIELD system, ensure the ResiSHIELD is fully isolated electrically and hydraulically before commencing. Note that the building will be without fire protection that the ResiSHIELD provides during this period, therefore the building owner and residents should be informed accordingly, and alternative measures put in place if necessary.

5.4 Spare Parts

WARNING

Use of any non-genuine spare parts may cause damage to equipment, damage to property and voiding of warranty.

- Use genuine, Dutypoint-approved spare parts only
 - If in doubt, contact dutypoint Service on 01452 300590
-

6. Troubleshooting

| Symptom | Possible Cause | Suggested Action |
|------------------------------------------------------|--------------------------------------------------------------------------------------------------|-------------------------------------------------------------------------------------|
| Controller will not turn on | No power to panel | Check power supply |
| | Internal wiring loom connectors are not fully engaged between PCB and screen | Check the wiring connectors are properly connected to the sockets on PCB and screen |
| Pump runs but there is no flow | pump is not fully primed | Turn the power off, loosen priming screw from top pump volute and release air |
| Pump produces correct pressure but does not turn off | System leak / open test valve | Check the system is fully sealed |
| | Pressure set point too high | Check the both pressure switch set points against system design |
| | Pressure switch fault | Replace pressure switch |
| Pump switches off before reaching required pressure | Pressure set point too low | Check the both pressure switch set points against system design |
| | Pressure switch fault | Replace pressure switch |
| System keeps going into fault - 'Sta-Err' | Minor system leak is causing the set to run more than the predetermined number of times per week | Check for system leaks |
| Pump will not run | Low water level signal | Check if low level device is connected and if this has been activated. |

| ITEM | DESCRIPTION |
|------|----------------------|
| 1 | AC ISOLATOR |
| 2 | PLC + HMI |
| 3 | HJ INTERFACE BOARD |
| 4 | TERMINALS |
| 5 | DOL CONTACTOR |
| 6 | MOTOR FUSE HOLDER |
| 7 | PANEL MOUNTING HOLES |

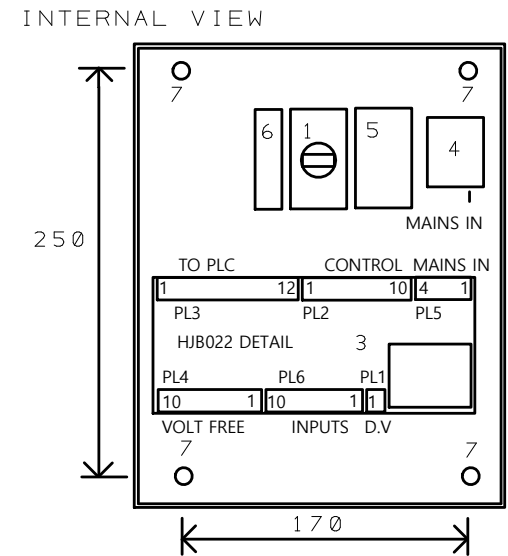
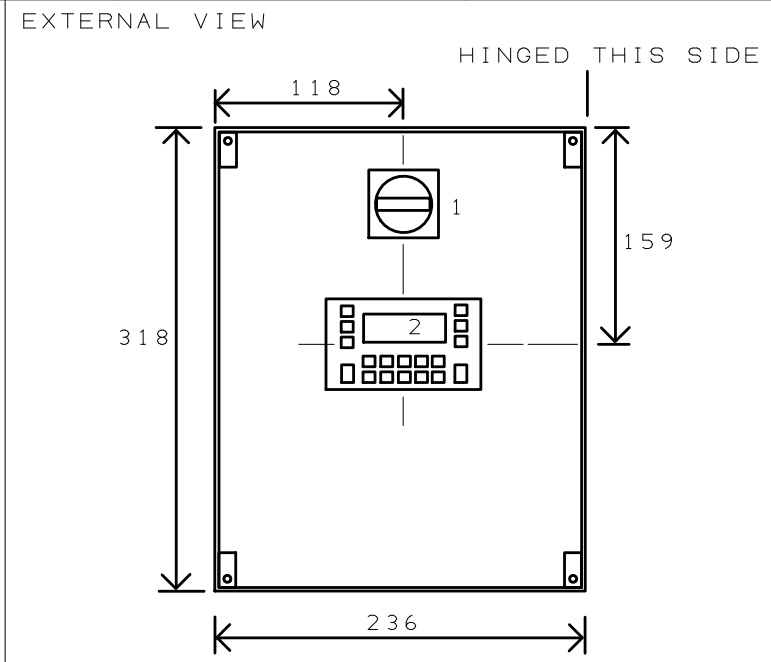
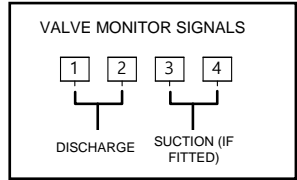
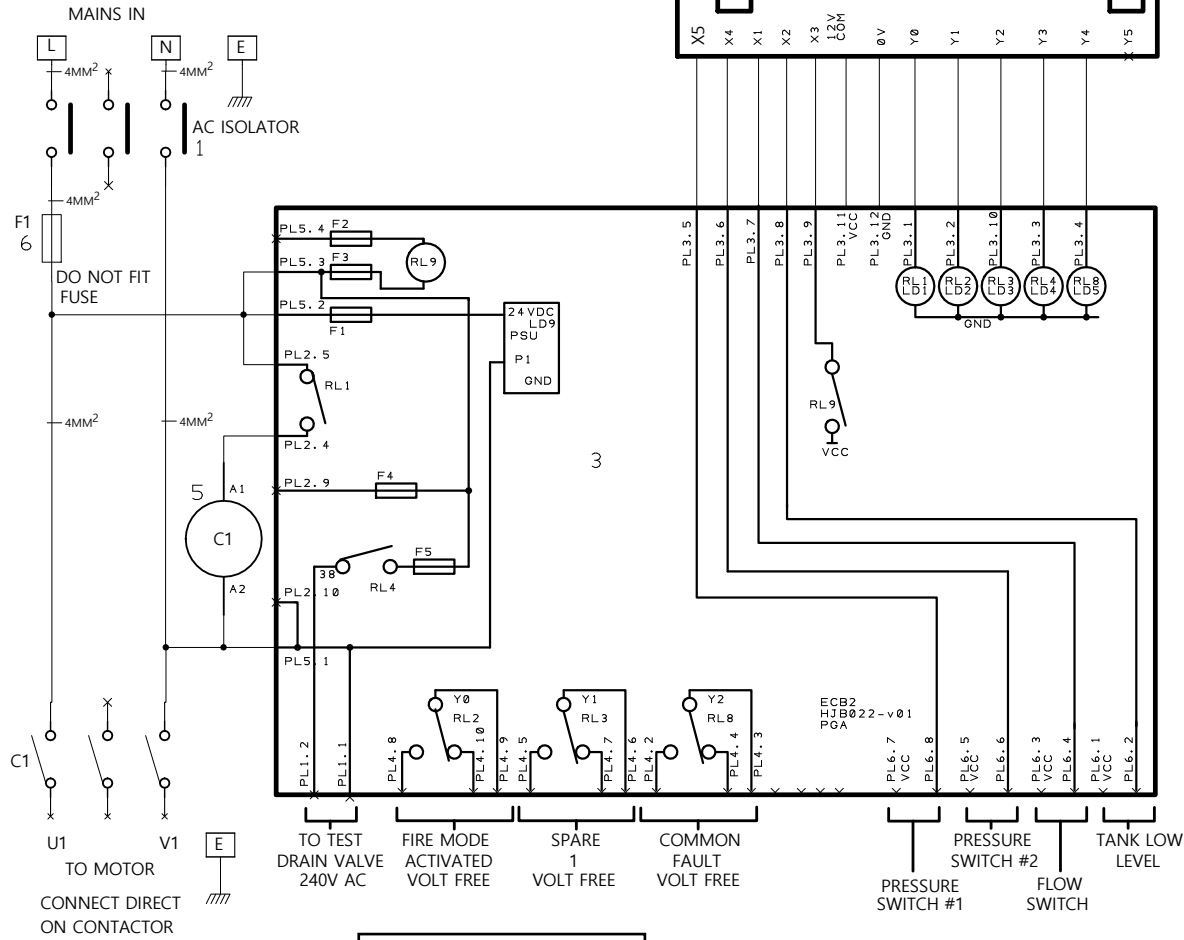

ABS ENCLOSURE
IP55 RATED

DO NOT SCALE

| | |
|----------------------------------------|-------------------------|
| PROJECT: H500 31-006218-000 DUTYPOINT | |
| DRAWING TITLE: DOL 1 PHASE RESIDENTIAL | |
| DRAWN BY: DAVID CARTER REVISION: 1 | |
| SHEET: 1 OF 1 | STATUS: PRODUCTION |
| DATE: 14.12.2022 | 31-006218-000 RS086 r 1 |



| ITEM | DESCRIPTION |
|------|----------------------|
| 1 | AC ISOLATOR |
| 2 | PLC + HMI |
| 3 | HJ INTERFACE BOARD |
| 4 | TERMINALS |
| 5 | DOL CONTACTOR |
| 6 | MOTOR FUSE HOLDER |
| 7 | PANEL MOUNTING HOLES |

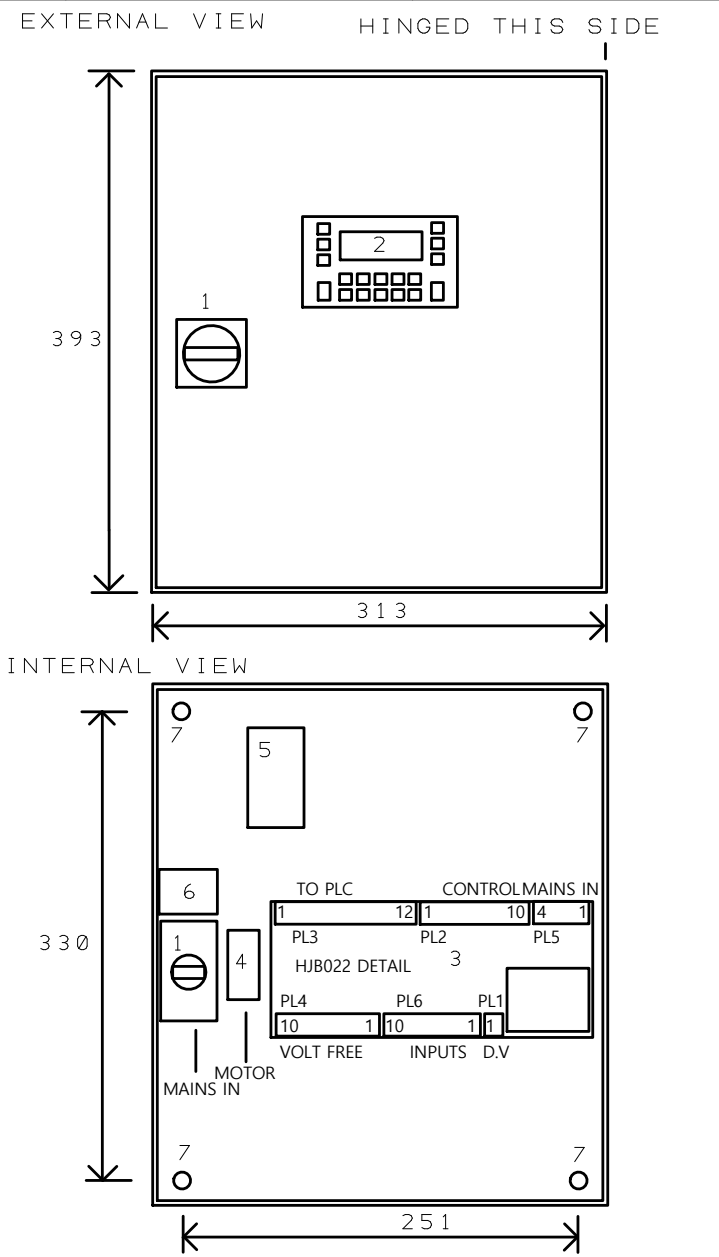
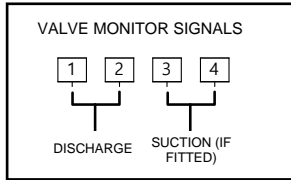
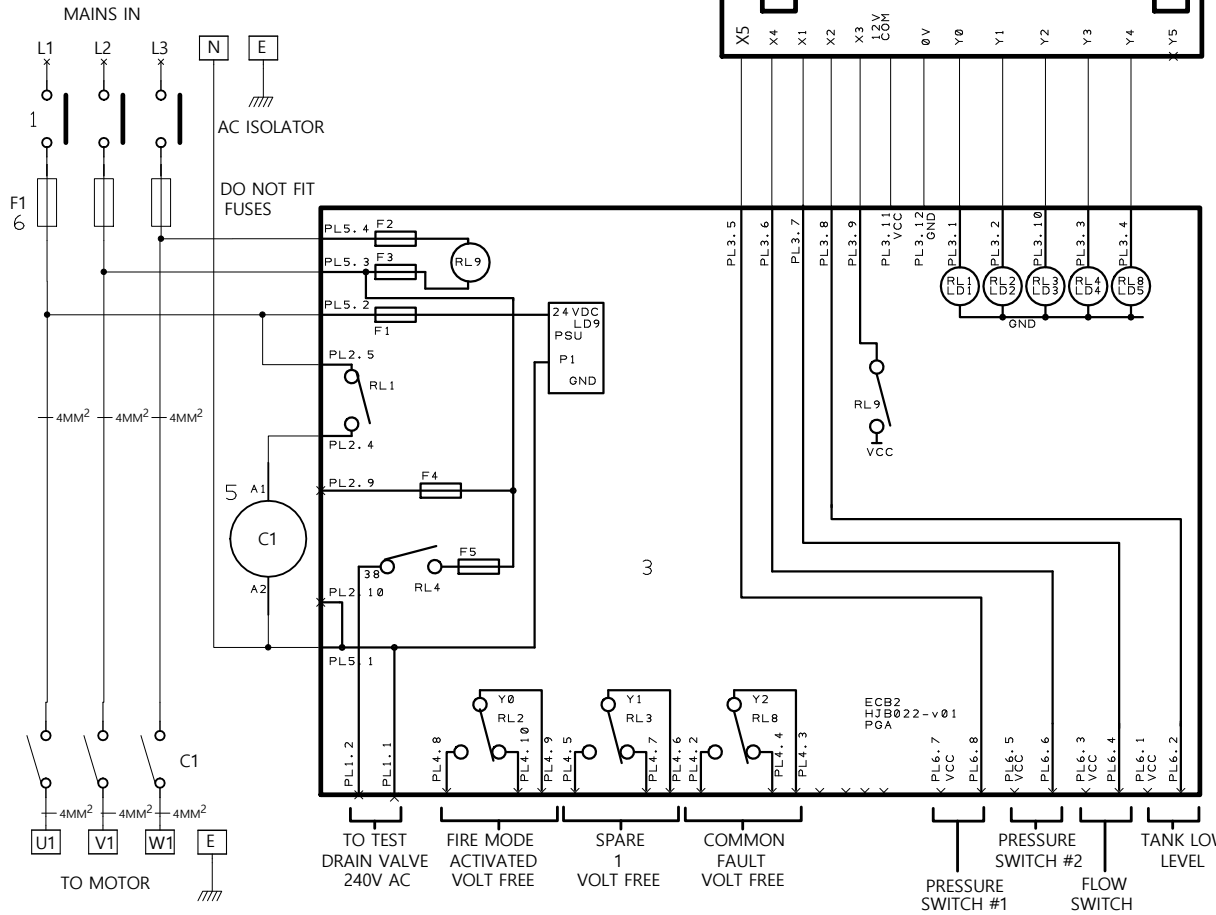

ABS ENCLOSURE
IP55 RATED

DO NOT SCALE

| | |
|----------------------------------------|------------------------|
| PROJECT: H500 31-006219-000 DUTYPOINT | |
| DRAWING TITLE: DOL 3 PHASE RESIDENTIAL | |
| DRAWN BY: DAVID CARTER REVISION: 1 | |
| SHEET: 1 OF 1 | STATUS: PRODUCTION |
| DATE: 14.12.2022 | 31-006219-000 RS086 r1 |



8. Dutypoint Standard Warranty

Your Dutypoint Systems standard product warranty is valid for a period of 12 months from date of delivery. The full terms and conditions are on the reverse of this certificate.

If you need to contact us regarding your warranty or any issue regarding your Dutypoint product, please contact our service department:

- Tel: +44(0)14523 00 590
- Email: service@dutypoint.com

Once your standard product warranty has expired, you may wish to take out our infinity service contract for an extended amount of cover. For more information visit our website: www.dutypoint.com/infinity

2.1 Terms and Conditions

- 1) The Company warrants that on delivery, and for a period of 12 months from the date of delivery, or such longer period as agreed by the Company in writing, (Warranty Period), the Goods shall:
 - a) conform in all material respects with their description as set out in the Agreement;
 - b) be free from material defects in design, material and workmanship; and
 - c) be of satisfactory quality (within the meaning of the Sale of Goods Act 1979).
- 2) Subject to Clause 3, if:
 - a) the Customer gives notice in writing to the Company during the Warranty Period within a reasonable time of discovery that some or all of the Goods do not comply with the warranty set out in Clause 1; and
 - b) the Company is given a reasonable opportunity to examine such Goods; and
 - c) the Customer (if asked to do so by the Company) returns such Goods to the Company's place of business, the Company shall, at its option, repair or replace the defective Goods, or refund the price of the defective Goods in full.
- 3) The Company shall not be liable for the failure of the Goods to comply with the warranty set out in Clause 1 in any of the following events:
 - a) the Customer makes any further use of such Goods after giving notice in accordance with Clause 2;
 - b) the defect arises because the Customer failed to follow the Company's oral or written instructions as to the storage, commissioning, installation, use and maintenance of the Goods or (if there are none) good trade practice regarding the same;
 - c) the defect arises as a result of the Company following any drawing, design or Specification supplied by the Customer;
 - d) the Customer alters or repairs such Goods without the written consent of the Company;
 - e) the defect arises as a result of fair wear and tear, wilful damage, negligence, or abnormal storage or working conditions; or
 - f) the defect arises as a result of the Customer's negligence or the Customer's breach of the Agreement.
- 4) Clause is the Customer's sole remedy in respect of the matters described therein.
- 5) The terms implied by sections 13 to 15 of the Sale of Goods Act 1979 are, to the fullest extent permitted by law, excluded from the Agreement.
- 6) The terms and conditions of the Agreement apply to any repaired or replacement Goods supplied by the Company.

9. Declaration of Conformity

UKCA & CE

We: Dutypoint Limited

Of: Quedgeley West Business Park, Gloucester, Gloucestershire, United Kingdom

in accordance with the following directives:

- 2006/42/EC : Machinery Directive
- S.I. 2008:1597 The Supply of Machinery (Safety) Regulations 2008
- 2014/30/EU : Electromagnetic Compatibility Directive
- S.I. 2016:1091 Electromagnetic Compatibility Regulations 2016
- 2014/35/EU : Low Voltage Directive.
- S.I. 2016:1101 Electromagnetic Compatibility Regulations 2016



Hereby declare that the equipment:

| | |
|---------------|---------------|
| Product Range | ResiSHIELD RZ |
|---------------|---------------|

Is in conformity with the applicable requirements of the following documents:

- EN 809:1998+A1:2009: Pumps and pump units for liquids - Common safety requirements
- EN 60204-1:2018: Safety of machinery - Electrical equipment of machines - Part 1: General requirements
- EN ISO 12100:2010: Safety of machinery - General principles for design
- EN 61000-6-2:2019: Electromagnetic compatibility (EMC) — Part 6-2: Generic standards
- EN 61000-6-4:2019: Electromagnetic compatibility (EMC) — Part 6-4: Generic standards
- BS9251:2021 : Fire sprinkler systems for domestic and residential occupancies - code of practice

I hereby declare that the equipment described above has been designed to comply with the relevant sections of the above referenced specifications. The unit complies with all applicable essential requirements of the directives.



Nigel Freeman, Director

Dutypoint Ltd
Unit A, Quedgeley West Business Park,
Hardwicke,
Gloucester
GL2 4PA
United Kingdom



Tel: +44 (0)1452 300590
www.dutypoint.com

DUTYPOINT

SETTING
THE BAR

Dutypoint Limited
Unit A, Quedgleley West Business Park,
Hardwicke,
Gloucester
GL2 4PA
United Kingdom

T:+44(0)1452300592

W: www.dutypoint.com