



**MADE IN
BRITAIN**[®]

Ultra-high efficient IE5 motored VRX cold water booster set



VRX

Variable speed twin, triple and quad pump high-efficiency and space-saving booster set.







PRODUCT OVERVIEW

- Ultra-high efficient IE5 motors and IES2 system efficiency
- Compact footprint
- Volt-free contact alarm signal for BMS connection
- Duty pump changeover timer to ensure consistent utilisation on all pumps
- Easy access to pumps for hassle-free maintenance
- Anti-vibration mounts are included as standard to reduce noise transmission
- Water approval accreditation pending

UK
CA

Key Features



-  QUIKSWAP™
-  HIRISE
-  BMS CONNECTABLE
-  FIRE SYSTEM UPGRADE
-  TRUESTANDBY™
-  BURST PIPE TECHNOLOGY
-  ANTI-VIBRATION FITTED



Specification

The Duty point VRX booster range boasts ultra-high efficiency within a very compact footprint, offering ultimate flexibility and whole-life cost savings. The inlet and discharge manifold on the VRX are located on the same side of the pump; these units can be installed in very confined spaces.

The VR family is engineered to very high standards and was the first ever booster set to be fully WRAS-approved.

PRODUCT OVERVIEW

- Multistage vertical pumps
- Low-water cut-out contacts in the panel
- Anti-vibration mounts reduce system noise
- Pressure set point adjustment
- Hours run log
- Local electrical isolation via internal MCB's
- IP55-rated control panel allows for simple and safe maintenance
- Cyclic duty changeover ensures even wear across pumps
- Common fault volt-free contact for connection to building management systems
- RS485 connections for connection to Modbus
- Water approval accreditation pending

RANGE PERFORMANCE

Number of pumps	2, 3 or 4
Flow range	0.5 - 36 l/s
Pressure range	2 - 16 bar
Max system pressure	16 bar
Controller type	Motor-mounted inverter
Max system temperature	23°C
Noise data	Motor at 2900 rpm < 70LpA (dB +/-3)

*More specific details available on request.

MATERIAL SPECIFICATION

Manifolds	AISI 304 stainless steel
Isolation valves	Nickel-plated brass
Non-return valves	AISI 304 stainless steel
Pressure transducers	AISI 304 stainless steel
Pump casing	AISI 304 stainless steel
Pump impellers	AISI 316 stainless steel
Mechanical seals	Silicon carbide, graphite, EPDM
Pressure vessels	Mild steel, WRAS approved
Base plate	Powder-coated mild steel

VRX2 - Twin Pump Duty/Standby Selector



PRESSURE REQUIRED (UNITS DISPLAYED IN LITRES PER SECOND)

2.5 bar		3.0 bar		3.5 bar		4.0 bar		4.5 bar		5.0 bar		5.5 bar		6.0 bar	
Ref	Flow rate	Ref	Flow rate	Ref	Flow rate	Ref	Flow rate	Ref	Flow rate	Ref	Flow rate	Ref	Flow rate	Ref	Flow rate
1	1.6	1	1.7	1	1.9	1	2.1	1	2.2	1	2.4	1	2.6	1	2.7
2	3.6	2	4.1	2	4.5	2	4.5	2	4.2	2	4	2	3.8	2	3.6
4	7.5	4	6.6	4	5.4	5	6.9	3	4.6	3	4.5	3	4.3	3	4.2
9	8.6	5	7.7	5	7.3	6	7.6	5	6.4	5	5.8	6	6.6	6	6.2
		9	8.1	6	7.9	10	8.3	6	7.2	6	6.9	7	7.5	7	7.2
		10	9.1	10	8.8	11	9.2	7	7.8	7	7.7	11	8.4	11	8.1
								11	9	11	8.8			12	9

6.5 bar		7.0 bar		7.5 bar		8.0 bar		8.5 bar		9.0 bar		9.5 bar		10.0 bar	
Ref	Flow rate	Ref	Flow rate	Ref	Flow rate	Ref	Flow rate	Ref	Flow rate	Ref	Flow rate	Ref	Flow rate	Ref	Flow rate
1	2.6	1	2.5	1	2.5	1	2.4	1	2.3	1	2.2	1	2.1	1	2
2	3.3	2	3.1	2	2.8	2	2.6	2	2.4	2	2.2	3	2.9	3	2.7
3	4	3	3.8	3	3.6	3	3.4	3	3.3	3	3.1	7	5.6	7	5.3
6	5.9	6	5.6	6	5.2	6	4.8	6	4.5	6	4.2	12	7.8	12	7.6
7	7	7	6.8	7	6.6	7	6.3	7	6.1	7	5.8				
11	7.8	11	7.4	11	7.1	11	6.7	11	6.4	11	6				
12	9.2	12	9	12	8.8	12	8.6	12	8.3	12	8.1				

VR MODEL

Ref	Model no.
1	VRX2-05-030T
2	VRX2-10-030T
3	VRX2-10-040T
4	VRX2-15-030T
5	VRX2-15-040T
6	VRX2-15-055T
7	VRX2-15-075T
8	VRX2-22-030T
9	VRX2-22-040T
10	VRX2-22-055T
11	VRX2-22-075T
12	VRX2-22-110T



VRX2 - Twin Pump Duty/Assist Selector



PRESSURE REQUIRED (UNITS DISPLAYED IN LITRES PER SECOND)

2.5 bar		3.0 bar		3.5 bar		4.0 bar		4.5 bar		5.0 bar		5.5 bar		6.0 bar	
Ref	Flow rate	Ref	Flow rate	Ref	Flow rate	Ref	Flow rate	Ref	Flow rate	Ref	Flow rate	Ref	Flow rate	Ref	Flow rate
1	3.2	1	3.4	1	3.8	1	4.2	1	4.4	1	4.8	1	5.1	1	5.3
2	7.1	2	8.1	2	8.9	2	8.9	2	8.3	2	7.9	2	7.5	2	7.1
4	14.9	4	13.1	4	10.7	5	13.7	3	9.1	3	8.9	3	8.5	3	8.3
9	17	5	15.2	5	14.5	6	15	5	12.7	5	11.5	6	13.1	6	12.3
		9	16	6	15.6	10	16.4	6	14.3	6	13.7	7	14.9	7	14.3
		10	18	10	17.4	11	18.2	7	15.4	7	15.2	11	16.6	11	16
								11	17.8	11	17.4			12	17.8

6.5 bar		7.0 bar		7.5 bar		8.0 bar		8.5 bar		9.0 bar		9.5 bar		10.0 bar	
Ref	Flow rate	Ref	Flow rate	Ref	Flow rate	Ref	Flow rate	Ref	Flow rate	Ref	Flow rate	Ref	Flow rate	Ref	Flow rate
1	5.1	1	5	1	5	1	4.8	1	4.6	1	4.4	1	4.2	1	4
2	6.5	2	6.1	2	5.5	2	5.1	2	4.8	2	4.4	3	5.7	3	5.3
3	7.9	3	7.5	3	7.1	3	6.7	3	6.5	3	6.1	7	11.1	7	10.5
6	11.7	6	11.1	6	10.3	6	9.5	6	8.9	6	8.3	12	15.4	12	15
7	13.9	7	13.5	7	13.1	7	12.5	7	12.1	7	11.5				
11	15.4	11	14.7	11	14.1	11	13.3	11	12.7	11	11.9				
12	18.2	12	17.8	12	17.4	12	17	12	16.4	12	16				

VR MODEL

Ref	Model no.
1	VRX2-05-030T
2	VRX2-10-030T
3	VRX2-10-040T
4	VRX2-15-030T
5	VRX2-15-040T
6	VRX2-15-055T
7	VRX2-15-075T
8	VRX2-22-030T
9	VRX2-22-040T
10	VRX2-22-055T
11	VRX2-22-075T
12	VRX2-22-110T

VRX3 - Triple Pump Duty/Assist/Standby Selector



PRESSURE REQUIRED (UNITS DISPLAYED IN LITRES PER SECOND)

2.5 bar		3.0 bar		3.5 bar		4.0 bar		4.5 bar		5.0 bar		5.5 bar		6.0 bar	
Ref	Flow rate	Ref	Flow rate	Ref	Flow rate	Ref	Flow rate	Ref	Flow rate	Ref	Flow rate	Ref	Flow rate	Ref	Flow rate
1	3.2	1	3.4	1	3.8	1	4.2	1	4.4	1	4.8	1	5.1	1	5.3
2	7.1	2	8.1	2	8.9	2	8.9	2	8.3	2	7.9	2	7.5	2	7.1
4	14.9	4	13.1	4	10.7	5	13.7	3	9.1	3	8.9	3	8.5	3	8.3
9	17	5	15.2	5	14.5	6	15	5	12.7	5	11.5	6	13.1	6	12.3
		9	16	6	15.6	10	16.4	6	14.3	6	13.7	7	14.9	7	14.3
		10	18	10	17.4	11	18.2	7	15.4	7	15.2	11	16.6	11	16
								11	17.8	11	17.4			12	17.8

6.5 bar		7.0 bar		7.5 bar		8.0 bar		8.5 bar		9.0 bar		9.5 bar		10.0 bar	
Ref	Flow rate	Ref	Flow rate	Ref	Flow rate	Ref	Flow rate	Ref	Flow rate	Ref	Flow rate	Ref	Flow rate	Ref	Flow rate
1	5.1	1	5	1	5	1	4.8	1	4.6	1	4.4	1	4.2	1	4
2	6.5	2	6.1	2	5.5	2	5.1	2	4.8	2	4.4	3	5.7	3	5.3
3	7.9	3	7.5	3	7.1	3	6.7	3	6.5	3	6.1	7	11.1	7	10.5
6	11.7	6	11.1	6	10.3	6	9.5	6	8.9	6	8.3	12	15.4	12	15
7	13.9	7	13.5	7	13.1	7	12.5	7	12.1	7	11.5				
11	15.4	11	14.7	11	14.1	11	13.3	11	12.7	11	11.9				
12	18.2	12	17.8	12	17.4	12	17	12	16.4	12	16				

VR MODEL

Ref	Model no.
1	VRX3-05-030T
2	VRX3-10-030T
3	VRX3-10-040T
4	VRX3-15-030T
5	VRX3-15-040T
6	VRX3-15-055T
7	VRX3-15-075T
8	VRX3-22-030T
9	VRX3-22-040T
10	VRX3-22-055T
11	VRX3-22-075T
12	VRX3-22-110T



VRX3 - Triple Pump Duty/Assist/Assist Selector



PRESSURE REQUIRED (UNITS DISPLAYED IN LITRES PER SECOND)

2.5 bar		3.0 bar		3.5 bar		4.0 bar		4.5 bar		5.0 bar		5.5 bar		6.0 bar	
Ref	Flow rate	Ref	Flow rate	Ref	Flow rate	Ref	Flow rate	Ref	Flow rate	Ref	Flow rate	Ref	Flow rate	Ref	Flow rate
1	4.7	1	5	1	5.6	1	6.2	1	6.5	1	7.1	1	7.6	1	7.9
2	10.6	2	12.1	2	13.2	2	13.2	2	12.3	2	11.8	2	11.2	2	10.6
4	22.1	4	19.4	4	15.9	5	20.3	3	13.5	3	13.2	3	12.6	3	12.3
9	25.3	5	22.6	5	21.5	6	22.3	5	18.8	5	17.1	6	19.4	6	18.2
		9	23.8	6	23.2	10	24.4	6	21.2	6	20.3	7	22.1	7	21.2
		10	26.8	10	25.9	11	27	7	22.9	7	22.6	11	24.7	11	23.8
								11	26.5	11	25.9			12	26.5

6.5 bar		7.0 bar		7.5 bar		8.0 bar		8.5 bar		9.0 bar		9.5 bar		10.0 bar	
Ref	Flow rate	Ref	Flow rate	Ref	Flow rate	Ref	Flow rate	Ref	Flow rate	Ref	Flow rate	Ref	Flow rate	Ref	Flow rate
1	7.6	1	7.4	1	7.4	1	7.1	1	6.8	1	6.5	1	6.2	1	5.9
2	9.7	2	9.1	2	8.2	2	7.6	2	7.1	2	6.5	3	8.5	3	7.9
3	11.8	3	11.2	3	10.6	3	10	3	9.7	3	9.1	7	16.5	7	15.6
6	17.3	6	16.5	6	15.3	6	14.1	6	13.2	6	12.3	12	22.9	12	22.3
7	20.6	7	20	7	19.4	7	18.5	7	17.9	7	17.1				
11	22.9	11	21.8	11	20.9	11	19.7	11	18.8	11	17.6				
12	27	12	26.5	12	25.9	12	25.3	12	24.4	12	23.8				

VR MODEL

Ref	Model no.
1	VRX3-05-030T
2	VRX3-10-030T
3	VRX3-10-040T
4	VRX3-15-030T
5	VRX3-15-040T
6	VRX3-15-055T
7	VRX3-15-075T
8	VRX3-22-030T
9	VRX3-22-040T
10	VRX3-22-055T
11	VRX3-22-075T
12	VRX3-22-110T

VRX4 - Quad Pump Duty/Assist/Assist /Standby Selector



PRESSURE REQUIRED (UNITS DISPLAYED IN LITRES PER SECOND)

2.5 bar		3.0 bar		3.5 bar		4.0 bar		4.5 bar		5.0 bar		5.5 bar		6.0 bar	
Ref	Flow rate	Ref	Flow rate	Ref	Flow rate	Ref	Flow rate	Ref	Flow rate	Ref	Flow rate	Ref	Flow rate	Ref	Flow rate
1	4.7	1	5	1	5.6	1	6.2	1	6.5	1	7.1	1	7.6	1	7.9
2	10.6	2	12.1	2	13.2	2	13.2	2	12.3	2	11.8	2	11.2	2	10.6
4	22.1	4	19.4	4	15.9	5	20.3	3	13.5	3	13.2	3	12.6	3	12.3
9	25.3	5	22.6	5	21.5	6	22.3	5	18.8	5	17.1	6	19.4	6	18.2
		9	23.8	6	23.2	10	24.4	6	21.2	6	20.3	7	22.1	7	21.2
		10	26.8	10	25.9	11	27	7	22.9	7	22.6	11	24.7	11	23.8
								11	26.5	11	25.9			12	26.5

6.5 bar		7.0 bar		7.5 bar		8.0 bar		8.5 bar		9.0 bar		9.5 bar		10.0 bar	
Ref	Flow rate	Ref	Flow rate	Ref	Flow rate	Ref	Flow rate	Ref	Flow rate	Ref	Flow rate	Ref	Flow rate	Ref	Flow rate
1	7.6	1	7.4	1	7.4	1	7.1	1	6.8	1	6.5	1	6.2	1	5.9
2	9.7	2	9.1	2	8.2	2	7.6	2	7.1	2	6.5	3	8.5	3	7.9
3	11.8	3	11.2	3	10.6	3	10	3	9.7	3	9.1	7	16.5	7	15.6
6	17.3	6	16.5	6	15.3	6	14.1	6	13.2	6	12.3	12	22.9	12	22.3
7	20.6	7	20	7	19.4	7	18.5	7	17.9	7	17.1				
11	22.9	11	21.8	11	20.9	11	19.7	11	18.8	11	17.6				
12	27	12	26.5	12	25.9	12	25.3	12	24.4	12	23.8				

VR MODEL

Ref	Model no.
1	VRX4-05-030T
2	VRX4-10-030T
3	VRX4-10-040T
4	VRX4-15-030T
5	VRX4-15-040T
6	VRX4-15-055T
7	VRX4-15-075T
8	VRX4-22-030T
9	VRX4-22-040T
10	VRX4-22-055T
11	VRX4-22-075T
12	VRX4-22-110T



VRX4 - Quad Pump Duty/Assist/Assist /Assist Selector



PRESSURE REQUIRED (UNITS DISPLAYED IN LITRES PER SECOND)

2.5 bar		3.0 bar		3.5 bar		4.0 bar		4.5 bar		5.0 bar		5.5 bar		6.0 bar	
Ref	Flow rate	Ref	Flow rate	Ref	Flow rate	Ref	Flow rate	Ref	Flow rate	Ref	Flow rate	Ref	Flow rate	Ref	Flow rate
1	6.2	1	6.6	1	7.4	1	8.1	1	8.5	1	9.3	1	10.1	1	10.5
2	14	2	15.9	2	17.5	2	17.5	2	16.3	2	15.5	2	14.7	2	14
4	29.1	4	25.6	4	21	5	26.8	3	17.8	3	17.5	3	16.7	3	16.3
9	33.4	5	29.9	5	28.3	6	29.5	5	24.8	5	22.5	6	25.6	6	24.1
		9	31.4	6	30.7	10	32.2	6	27.9	6	26.8	7	29.1	7	27.9
		10	35.3	10	34.1	11	35.7	7	30.3	7	29.9	11	32.6	11	31.4
								11	34.9	11	34.1			12	34.9

6.5 bar		7.0 bar		7.5 bar		8.0 bar		8.5 bar		9.0 bar		9.5 bar		10.0 bar	
Ref	Flow rate	Ref	Flow rate	Ref	Flow rate	Ref	Flow rate	Ref	Flow rate	Ref	Flow rate	Ref	Flow rate	Ref	Flow rate
1	10.1	1	9.7	1	9.7	1	9.3	1	8.9	1	8.5	1	8.1	1	7.8
2	12.8	2	12	2	10.9	2	10.1	2	9.3	2	8.5	3	11.3	3	10.5
3	15.5	3	14.7	3	14	3	13.2	3	12.8	3	12	7	21.7	7	20.6
6	22.9	6	21.7	6	20.2	6	18.6	6	17.5	6	16.3	12	30.3	12	29.5
7	27.2	7	26.4	7	25.6	7	24.4	7	23.7	7	22.5				
11	30.3	11	28.7	11	27.5	11	26	11	24.8	11	23.3				
12	35.7	12	34.9	12	34.1	12	33.4	12	32.2	12	31.4				

VR MODEL

Ref	Model no.
1	VRX4-05-030T
2	VRX4-10-030T
3	VRX4-10-040T
4	VRX4-15-030T
5	VRX4-15-040T
6	VRX4-15-055T
7	VRX4-15-075T
8	VRX4-22-030T
9	VRX4-22-040T
10	VRX4-22-055T
11	VRX4-22-075T
12	VRX4-22-110T

VRX2 Series

DRAWINGS AND DIMENSIONS

Model no.	Motor power (kW)	Supply voltage	Full load current (A)		Dimensions (mm)						Connections		Est. weight (kg)
			Per pump	Total	A	B	C	D	E	H	Suction	Discharge	
VRX2-05-030T	3	400/3/50	6.7	13.5	164	531	230	260	794	1510	DN50	DN50	210
VRX2-10-030T	3	400/3/50	6.7	13.5	169	380	171	204	794	1455	DN65	DN65	210
VRX2-10-040T	4	400/3/50	7.7	15.5	169	444	171	204	794	1455	DN65	DN65	210
VRX2-15-030T	3	400/3/50	6.7	13.5	179	438	128	170	794	1455	DN80	DN80	230
VRX2-15-040T	4	400/3/50	7.7	15.5	179	438	128	170	794	1455	DN80	DN80	230
VRX2-15-055T	5.5	400/3/50	10.1	20.2	179	438	128	170	794	1455	DN80	DN80	230
VRX2-15-075T	7.5	400/3/50	13.7	27.4	179	534	128	170	841	1675	DN80	DN80	260
VRX2-22-030T	3	400/3/50	6.7	13.5	179	438	128	170	794	1455	DN80	DN80	230
VRX2-22-040T	4	400/3/50	7.7	15.5	179	438	128	170	794	1455	DN80	DN80	230
VRX2-22-055T	5.5	400/3/50	10.1	20.2	179	438	128	170	794	1510	DN80	DN80	260
VRX2-22-075T	7.5	400/3/50	13.7	27.4	179	438	128	170	841	1565	DN80	DN80	290
VRX2-22-110T	11	400/3/50	19.8	39.6	179	534	128	170	841	1675	DN80	DN80	320

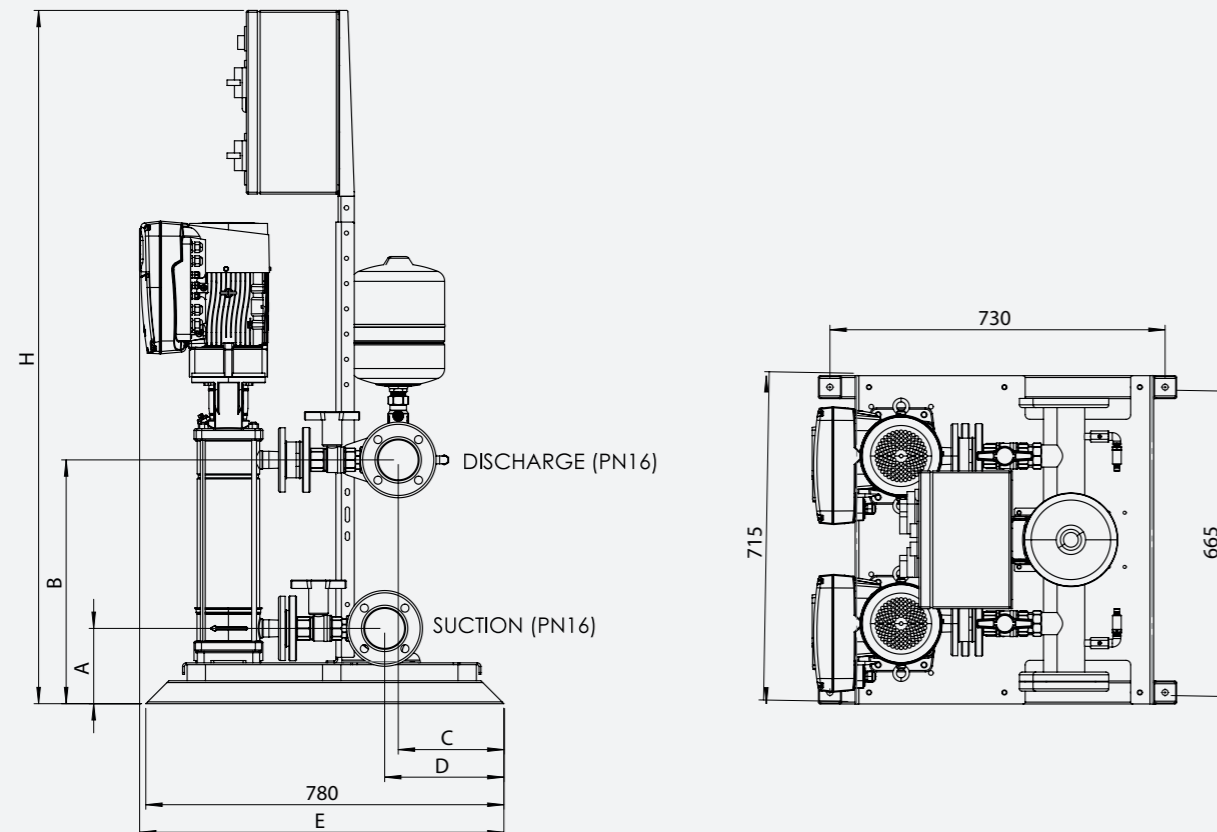

VRX3 Series

DRAWINGS AND DIMENSIONS

Model no.	Motor power (kW)	Supply voltage	Full load current (A)		Dimensions (mm)						Connections		Est. weight (kg)
			Per pump	Total	A	B	C	D	E	H	Suction	Discharge	
VRX3-05-030T	3	400/3/50	6.7	20.2	164	531	260	290	824	1510	DN50	DN50	240
VRX3-10-030T	3	400/3/50	6.7	20.2	169	380	201	234	824	1455	DN65	DN65	240
VRX3-10-040T	4	400/3/50	7.7	23.2	169	444	201	234	824	1455	DN65	DN65	240
VRX3-15-030T	3	400/3/50	6.7	20.2	179	438	158	200	824	1455	DN80	DN80	270
VRX3-15-040T	4	400/3/50	7.7	23.2	179	438	158	200	824	1455	DN80	DN80	270
VRX3-15-055T	5.5	400/3/50	10.1	30.3	179	438	158	200	824	1455	DN80	DN80	270
VRX3-15-075T	7.5	400/3/50	13.7	41.1	179	534	158	200	871	1675	DN80	DN80	300
VRX3-22-030T	3	400/3/50	6.7	20.2	179	438	158	200	824	1455	DN80	DN80	270
VRX3-22-040T	4	400/3/50	7.7	23.2	179	438	158	200	824	1455	DN80	DN80	270
VRX3-22-055T	5.5	400/3/50	10.1	30.3	179	438	158	200	824	1510	DN80	DN80	300
VRX3-22-075T	7.5	400/3/50	13.7	41.1	179	438	158	200	871	1565	DN80	DN80	330
VRX3-22-110T	11	400/3/50	19.8	59.4	179	534	158	200	871	1675	DN80	DN80	360

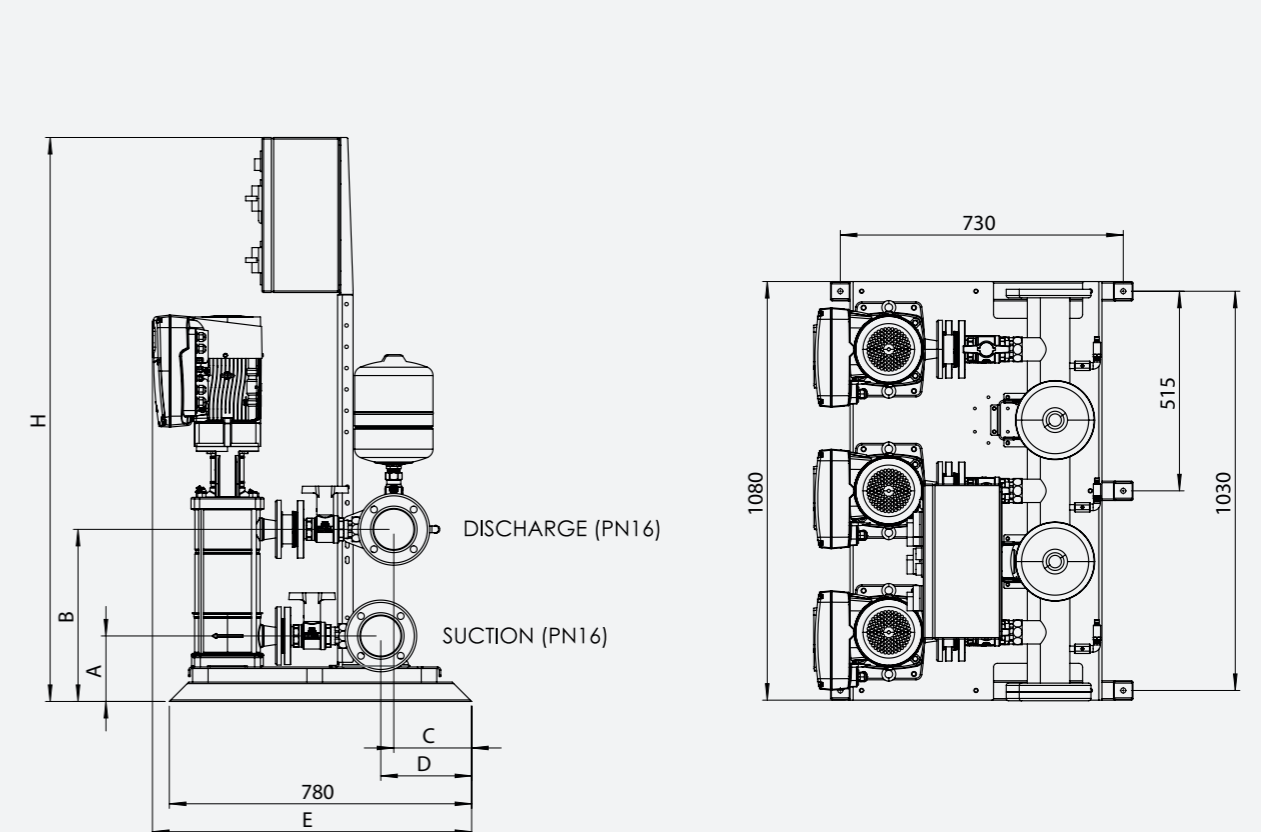

VRX4 Series

DRAWINGS AND DIMENSIONS

Model no.	Motor power (kW)	Supply voltage	Full load current (A)		Dimensions (mm)						Connections		Approx. dry weight (kg)
			Per pump	Total	A	B	C	D	E	H	Suction	Discharge	
VRX4-05-030T	3	400/3/50	6.7	27.0	164	531	272	302	844	1610	DN65	DN65	320
VRX4-10-030T	3	400/3/50	6.7	27.0	169	380	214	248	844	1555	DN80	DN80	320
VRX4-10-040T	4	400/3/50	7.7	30.9	169	444	214	248	844	1555	DN80	DN80	330
VRX4-15-030T	3	400/3/50	6.7	27.0	179	438	166	207	844	1555	DN100	DN100	390
VRX4-15-040T	4	400/3/50	7.7	30.9	179	438	166	207	844	1555	DN100	DN100	390
VRX4-15-055T	5.5	400/3/50	10.1	40.4	179	438	166	207	844	1555	DN100	DN100	400
VRX4-15-075T	7.5	400/3/50	13.7	54.8	179	534	166	207	891	1775	DN100	DN100	420
VRX4-22-030T	3	400/3/50	6.7	27.0	179	438	166	207	844	1555	DN100	DN100	390
VRX4-22-040T	4	400/3/50	7.7	30.9	179	438	166	207	844	1555	DN100	DN100	400
VRX4-22-055T	5.5	400/3/50	10.1	40.4	179	438	166	207	844	1610	DN100	DN100	420
VRX4-22-075T	7.5	400/3/50	13.7	54.8	179	438	166	207	891	1665	DN100	DN100	450
VRX4-22-110T	11	400/3/50	19.8	79.2	179	534	166	207	891	1775	DN100	DN100	480

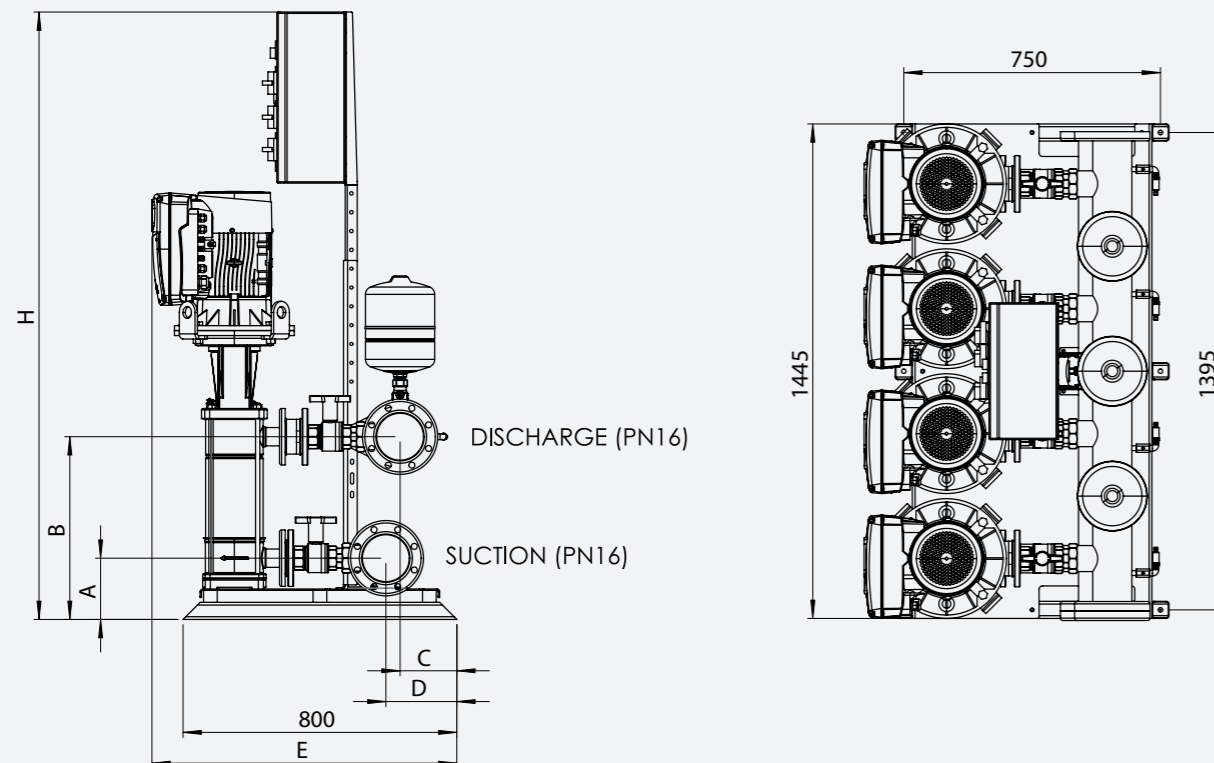

VRX_x-05 Series

SINGLE PUMP CURVES

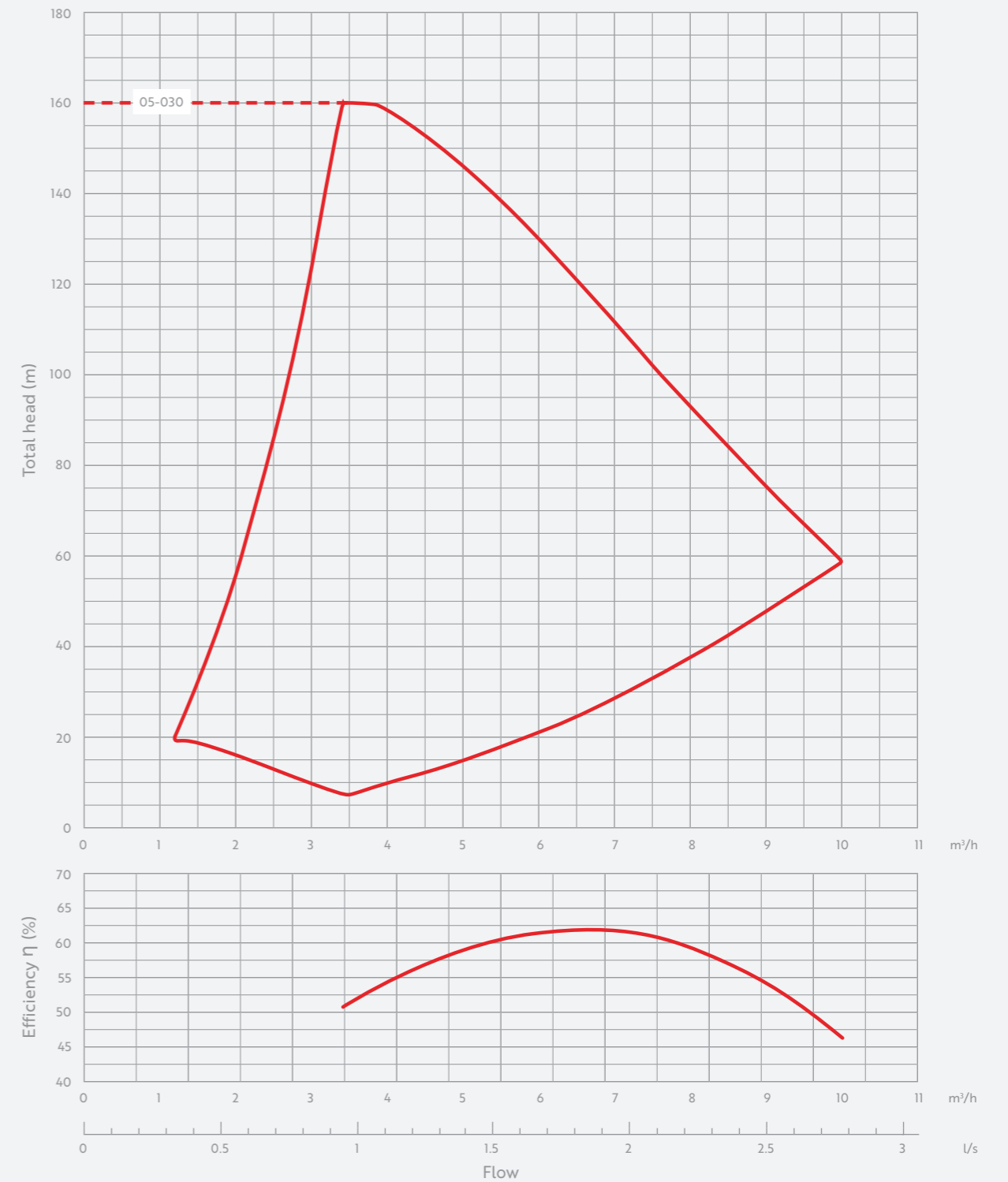

VRX_x-10 Series

SINGLE PUMP CURVES

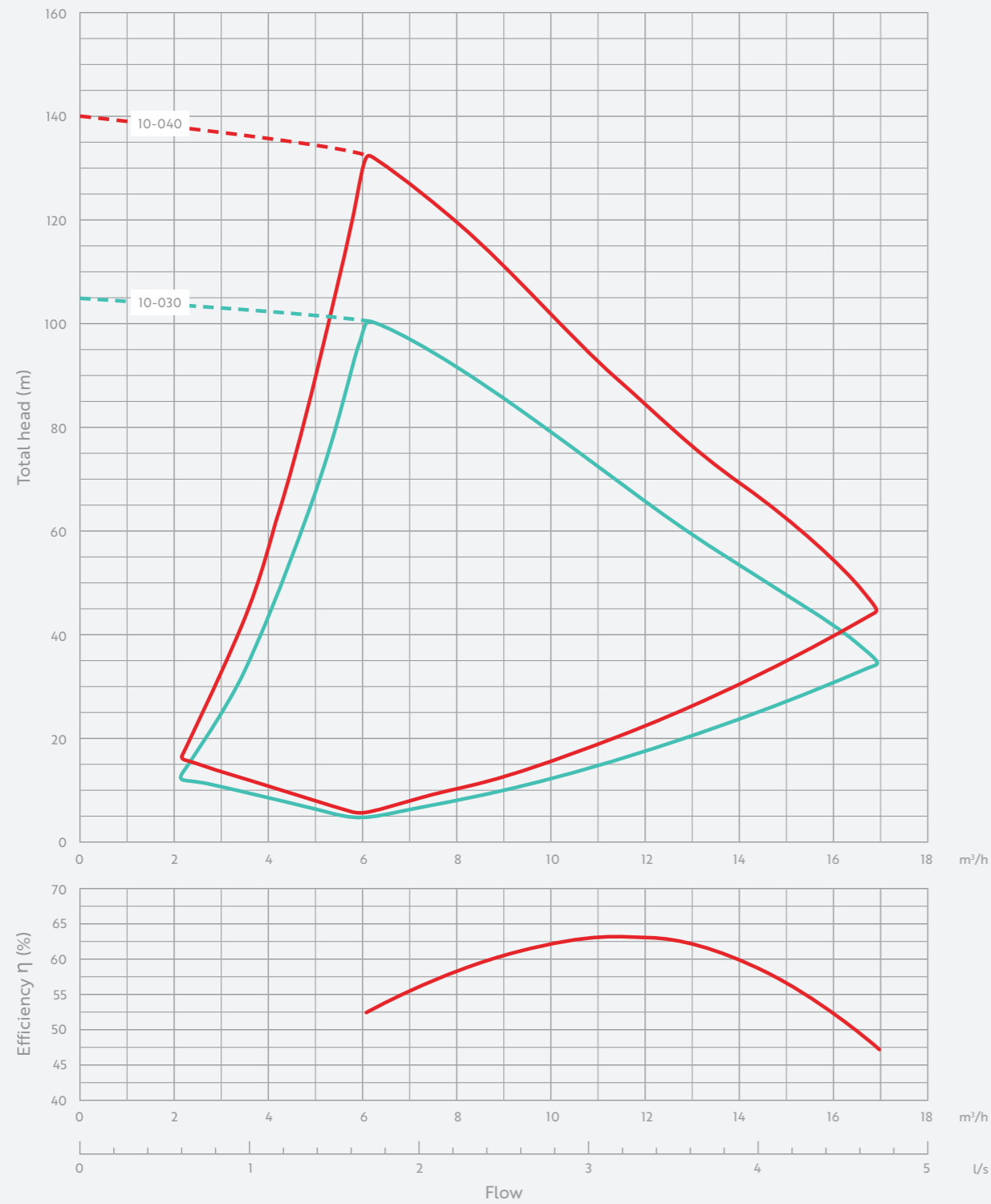

VRX_x-15 Series

SINGLE PUMP CURVES

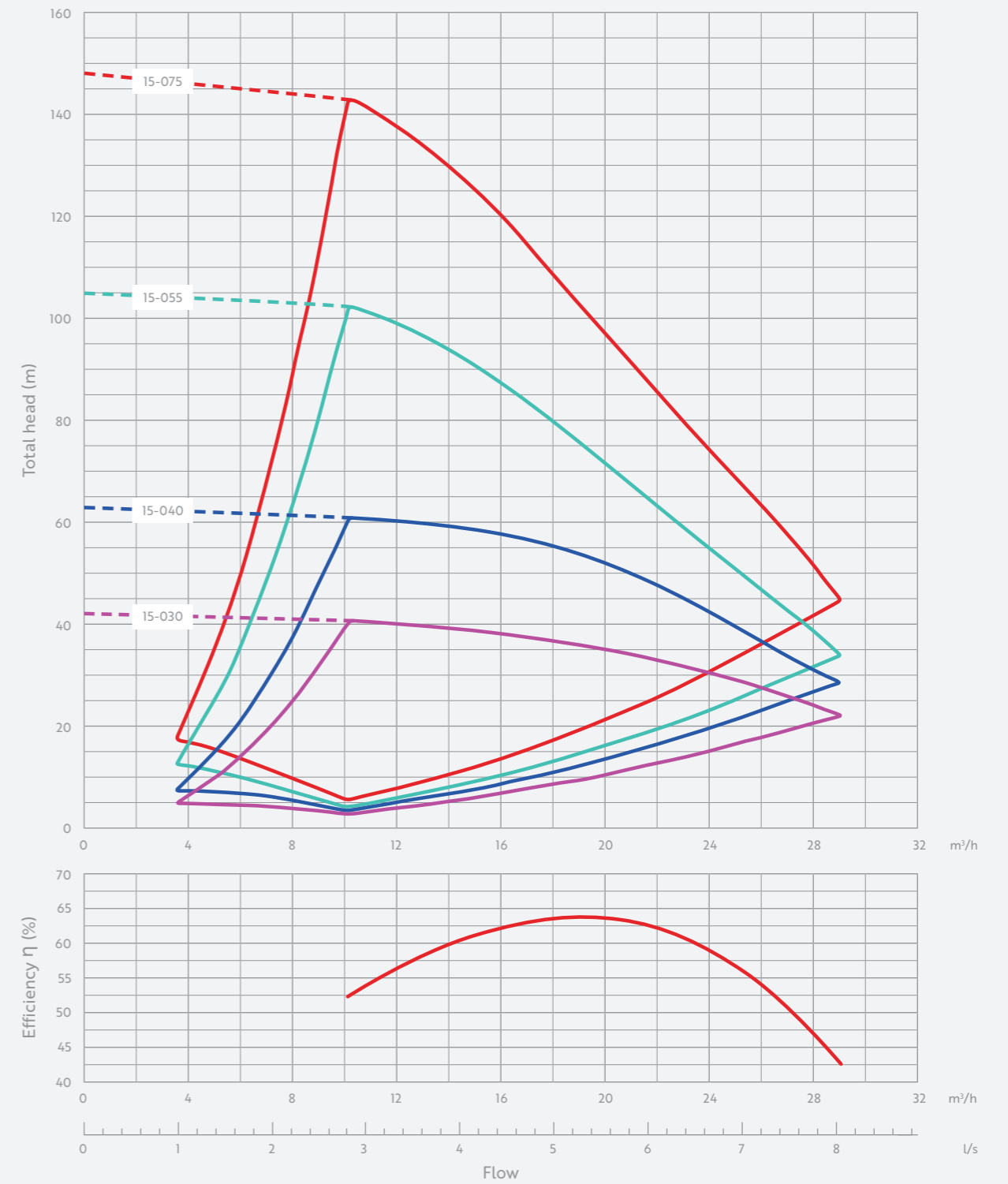

VRX_x-20 Series

SINGLE PUMP CURVES

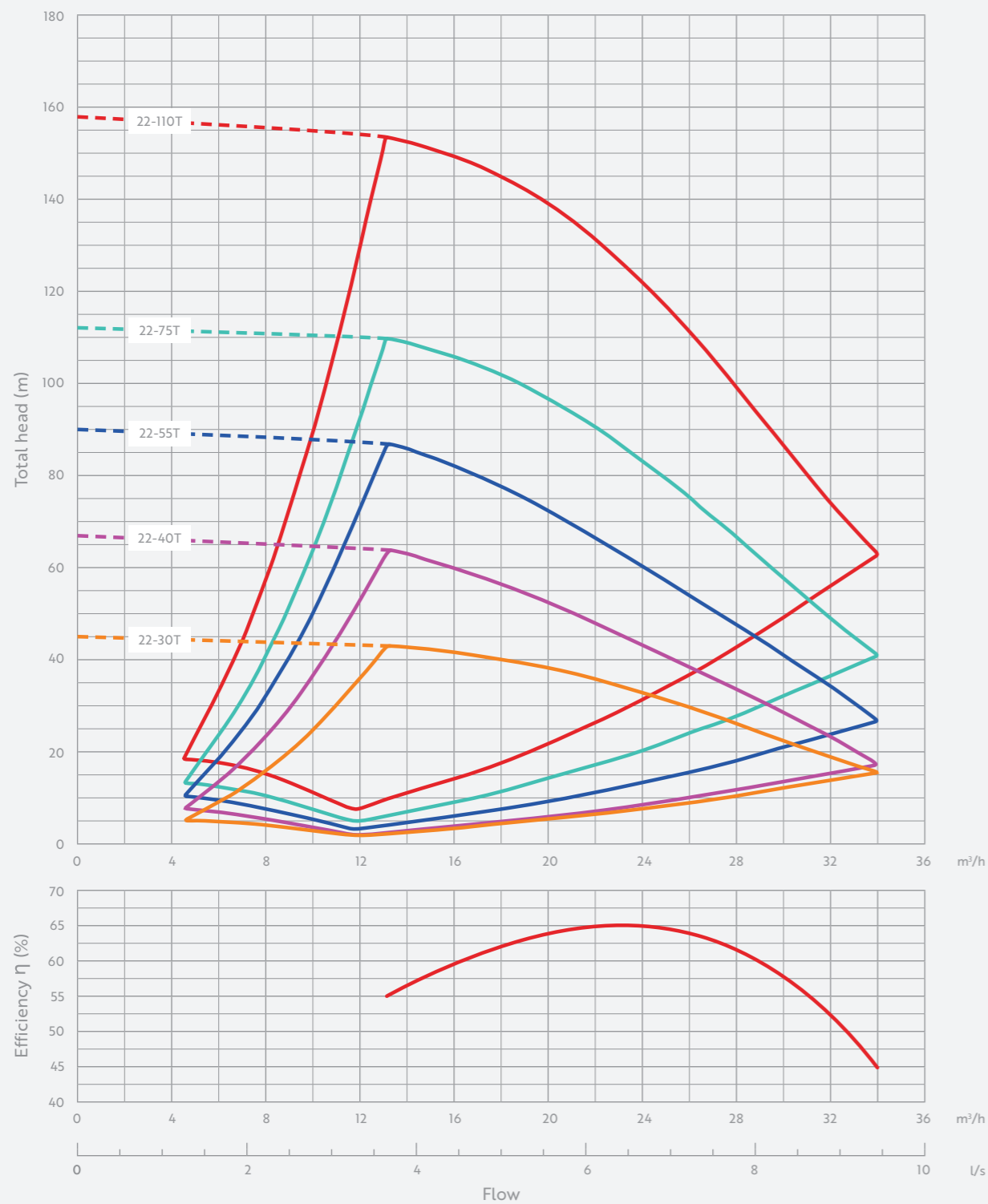

Fully bespoke booster sets

We offer a fully bespoke service, from design to commissioning and ongoing maintenance. Speak to our in-house design team, who will work with you to create a bespoke unit.



To discuss our bespoke booster sets, call us now on **01452 300110** or email enquiries@dutypoint.com



**Let's talk about the
VRX booster set**

01452 300110

ENQUIRIES@DUTYPOINT.COM

DUTYPOINT.COM