

8 7 6 5 4 3 2 1

Flowboost PRO E.K Range Four Pump Models & Dimensions

MODEL	SUCTION DN1	DISCHARGE DN2	A DEPTH mm	B HEIGHT mm	C DISCHARGE CENTER
PRO 4V.E.K.H.*.3005	3" BSP	2½" BSP	830	1280	570
PRO 4V.E.K.H.*.3007	3" BSP	2½" BSP	880	1280	570
PRO 4V.E.K.H.*.3009	3" BSP	2½" BSP	930	1280	570
PRO 4V.E.K.H.*.5004	3" BSP	2½" BSP	810	1280	570
PRO 4V.E.K.H.*.5005	3" BSP	2½" BSP	830	1280	570
PRO 4V.E.K.H.*.5006	3" BSP	2½" BSP	855	1280	570
PRO 4V.E.K.H.*.5007	3" BSP	2½" BSP	880	1280	570
PRO 4V.E.K.H.*.5009	3" BSP	2½" BSP	930	1280	570
PRO 4V.E.K.H.*.9004	3" BSP	3" BSP	845	1280	610
PRO 4V.E.K.H.*.9005	3" BSP	3" BSP	875	1280	610
PRO 4V.E.K.H.*.9006	3" BSP	3" BSP	905	1280	610
PRO 4V.E.K.H.*.9008	3" BSP	3" BSP	965	1280	610

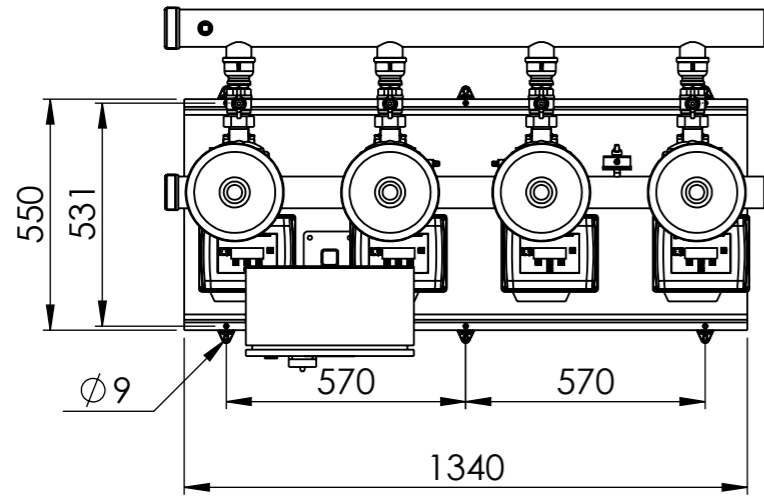

200mm MINIMUM HEADROOM REQUIRED

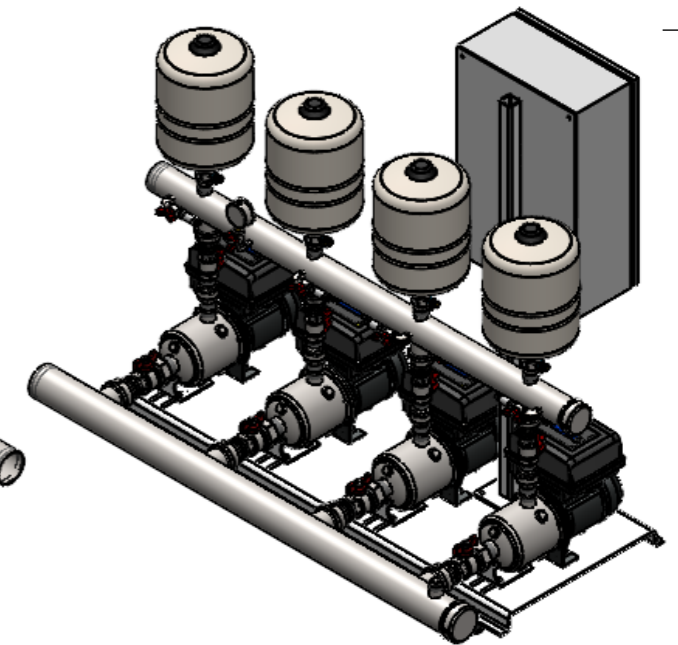
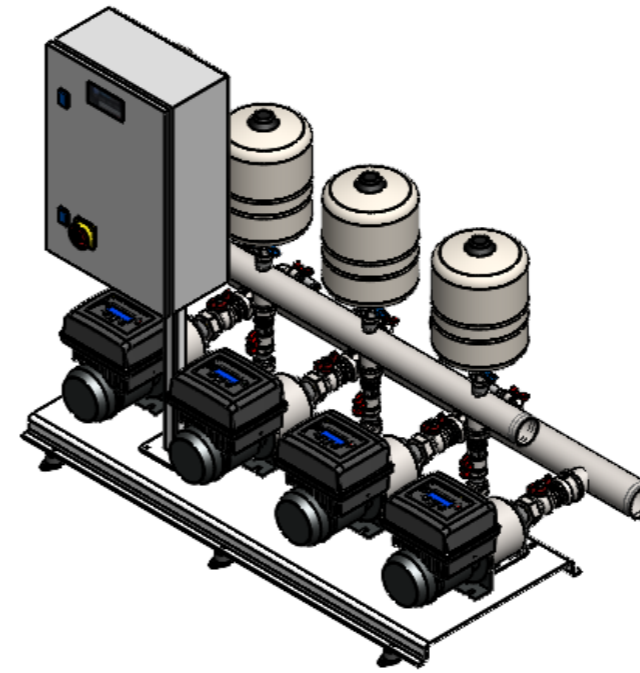
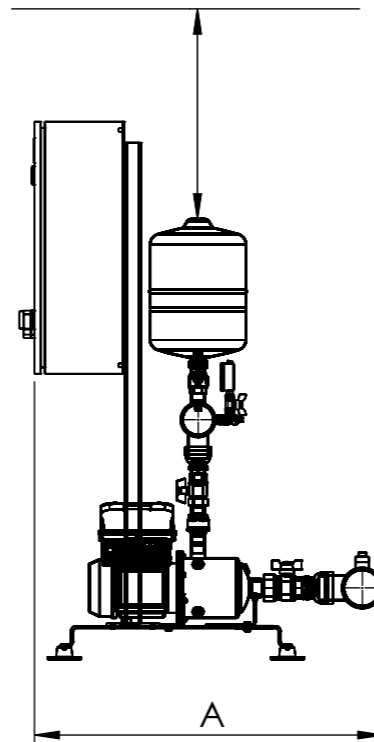
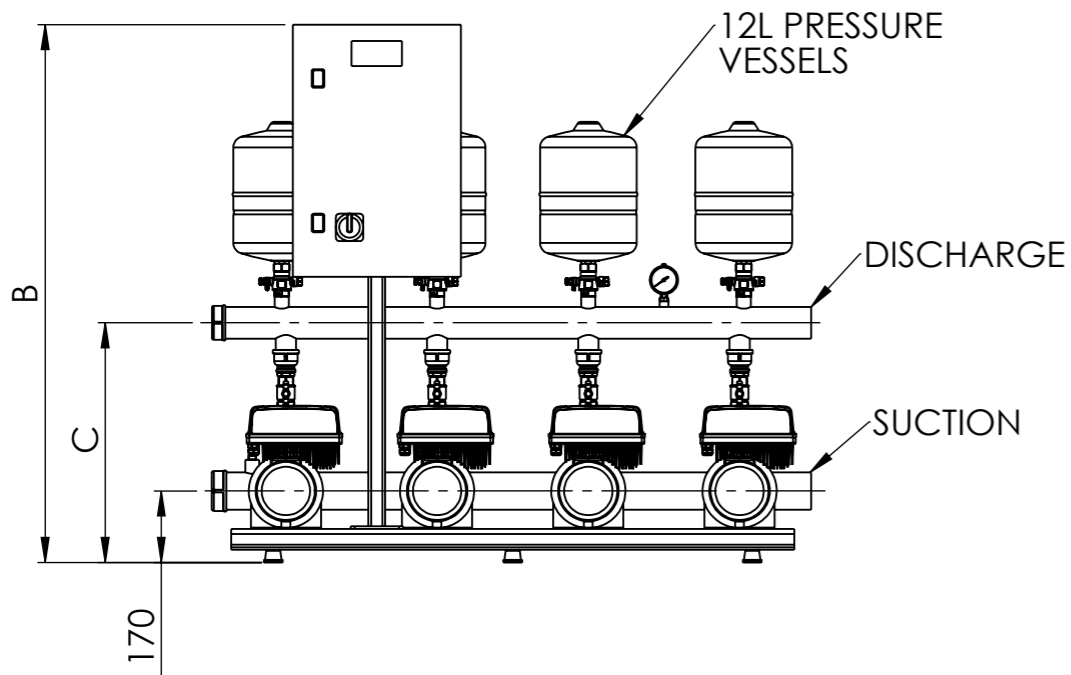

DUTYPOINT SETTING THE BAR

UNIT A, QUEDGELEY WEST BUSINESS PARK, HARDWICKE, GLOUCESTER GL2 4PA (T): 01452 300 110

PROPRIETARY & CONFIDENTIAL
DO NOT SCALE THIS DRAWING
IF IN DOUBT ASK

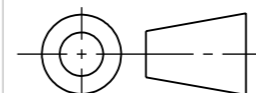

THIRD ANGLE

DRAWING NO:	5-005099-000	REV:	00.01
BIM NO:	XXX-XXX-XX-XX-XX-X-XX_XX_XX-XXXX-XX-XXX		
DESCRIPTION:	FLOWBOOST PRO E.K.H BOOSTER SET		
PROJECT NAME:			
MODEL NO.			
SERIAL NO.			
PROJECT NO.			
DRAWN BY:	JOHN FLORENCE	13/09/2024	SHEET NO. 3 OF 3
APPROVED BY:			SCALE: 1:18
			SHEET SIZE: A3
			WEIGHT KG:

8 7 6 5 4 3 2 1