



DUTYPOINT.COM

AIRBREAK VC CAT 5 BOOSTER SET



AirBREAK VC

Variable speed compact value set.

PRODUCT OVERVIEW

- Variable speed controller
- Durable steel enclosure design
- Volt-free contacts for common faults and pump running



Key Features

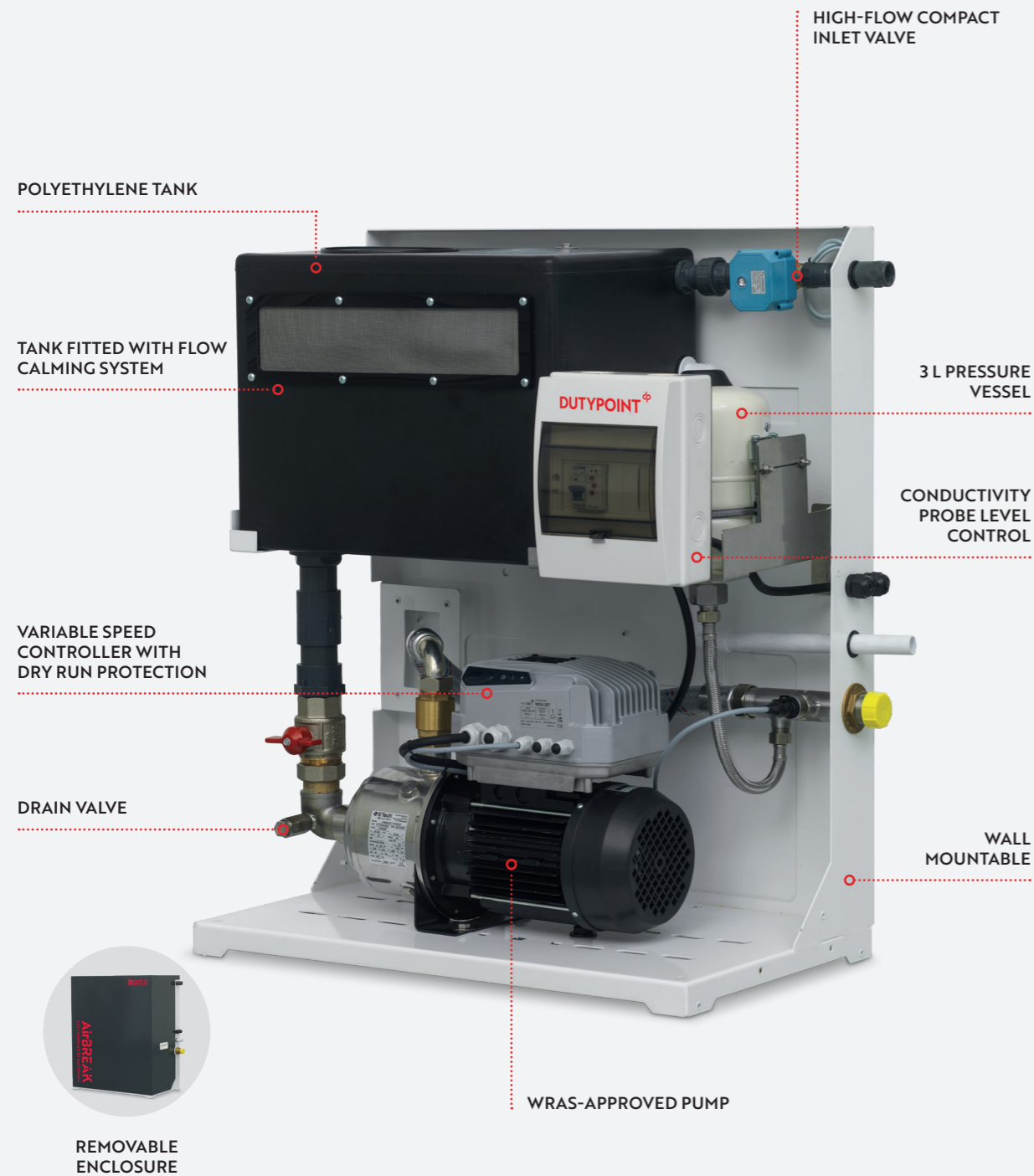

Specification

The AirBREAK VC is a variable-speed compact combined single pump break tank and end-suction booster pump designed for Category 5 backflow protection applications.

The set can be free-standing or wall-mounted and is a quiet running system with an integrated variable speed drive and a 3 L pressure vessel. The whole unit is housed within a robust powder-coated mild steel enclosure.

PRODUCT OVERVIEW

- Variable speed controller
- Durable steel enclosure design
- Motorised inlet valve for accurate, high-flow tank fill
- 36-litre nominal tank capacity
- Volt-free contacts for common faults and pump running
- Anti-seize technology

OPTIONS

- Weatherproof version with insulated enclosure, frost stat and heater
- High-level alarm VFC
- Weir overflow catch tray with a piped outlet to waste
- Drip tray
- Wall mounting bracket

RANGE PERFORMANCE

Flow range	0.2 - 1.8 l/s
Pressure range	1 - 8 bar
Pressure control type	Variable speed
Maximum system pressure	10 bar
Tank capacity (nominal)	36 litres
Power supply	230 V 1ph 50 Hz
IP rating	IP44
Inlet connection	½" BSP
Outlet connection	1" BSP
Air gap category	Category 5 (AB)
Overflow connection	25 mm
Tank construction	Polyethylene



VC03/05

DRAWINGS AND DIMENSIONS

Model no.	Motor power p2 (kW)	Supply voltage	FLC (A)	Total weight (kg)
VC1-03-004M	0.45	230/1/50	2.1	46
VC1-03-005M	0.55	230/1/50	2.4	46
VC1-03-007M	0.75	230/1/50	2.7	47
VC1-03-011M	1.1	230/1/50	3.6	50
VC1-03-015M	1.5	230/1/50	5.1	54
VC1-05-005M	0.55	230/1/50	2.5	46
VC1-05-007M	0.75	230/1/50	3.2	48
VC1-05-011M	1.1	230/1/50	3.7	49
VC1-05-015M	1.5	230/1/50	5.5	53

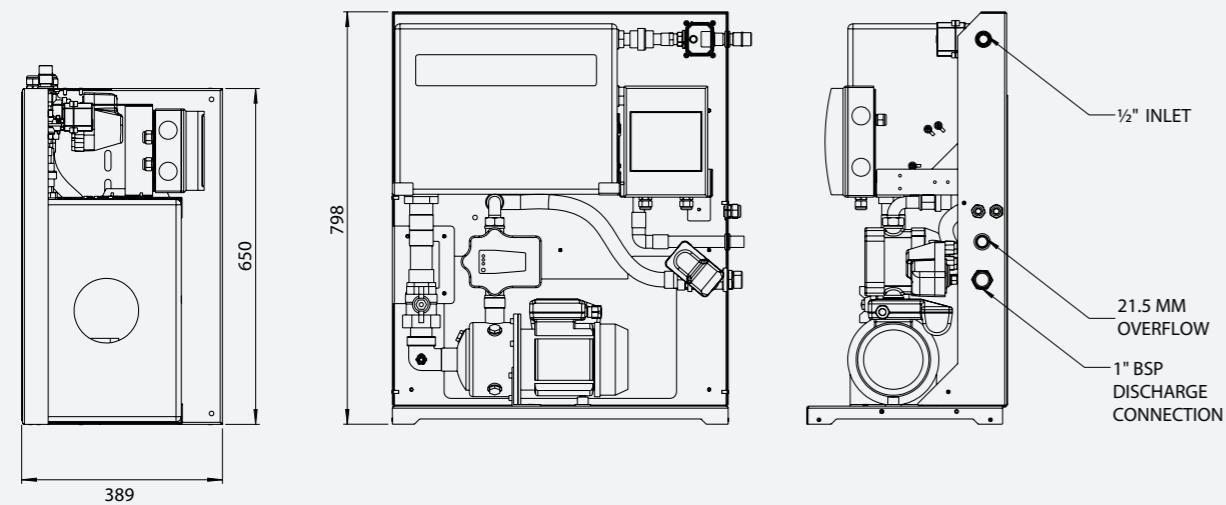

VC03 Series

SINGLE PUMP CURVES

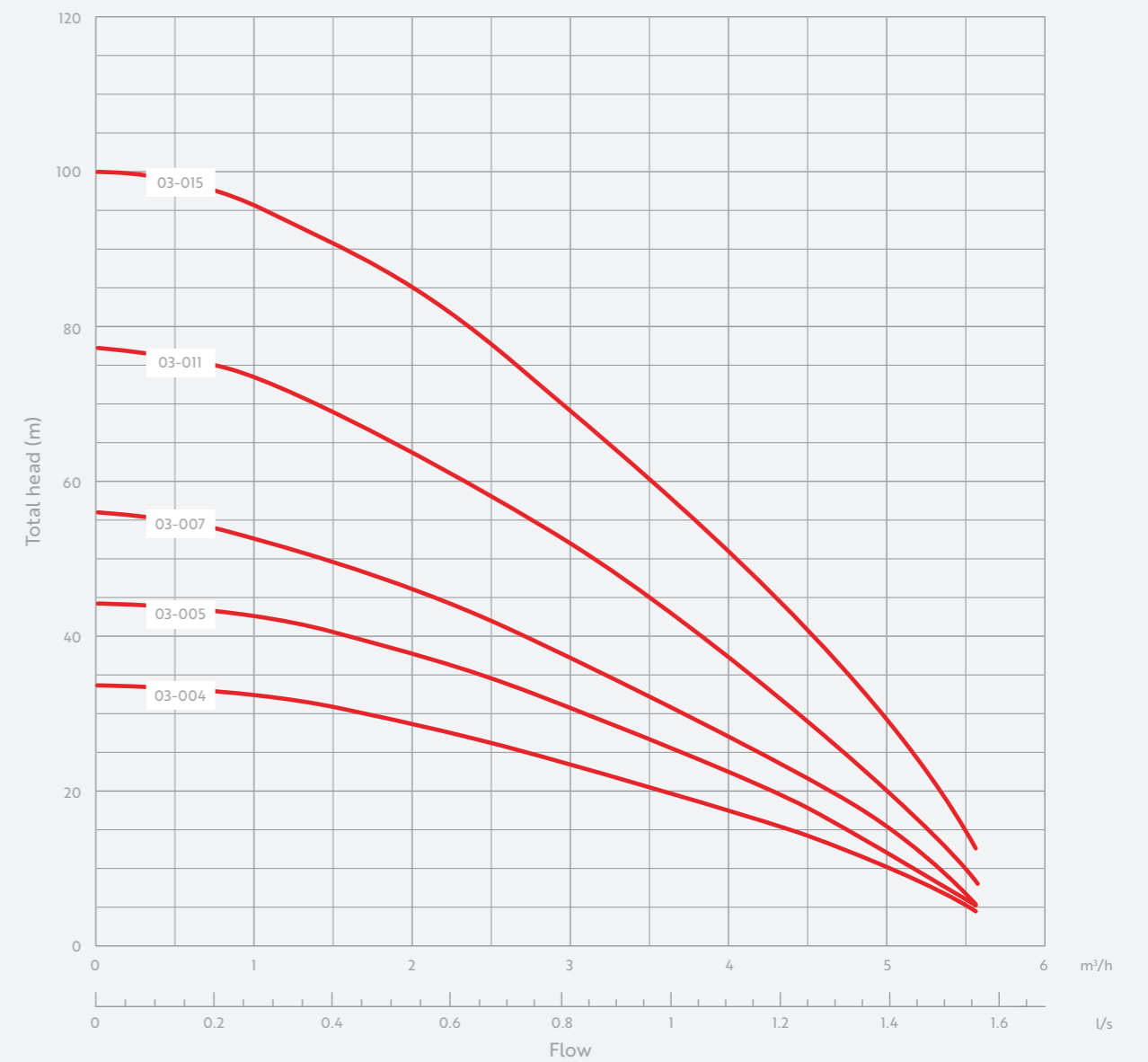

VC05 Series

SINGLE PUMP CURVES

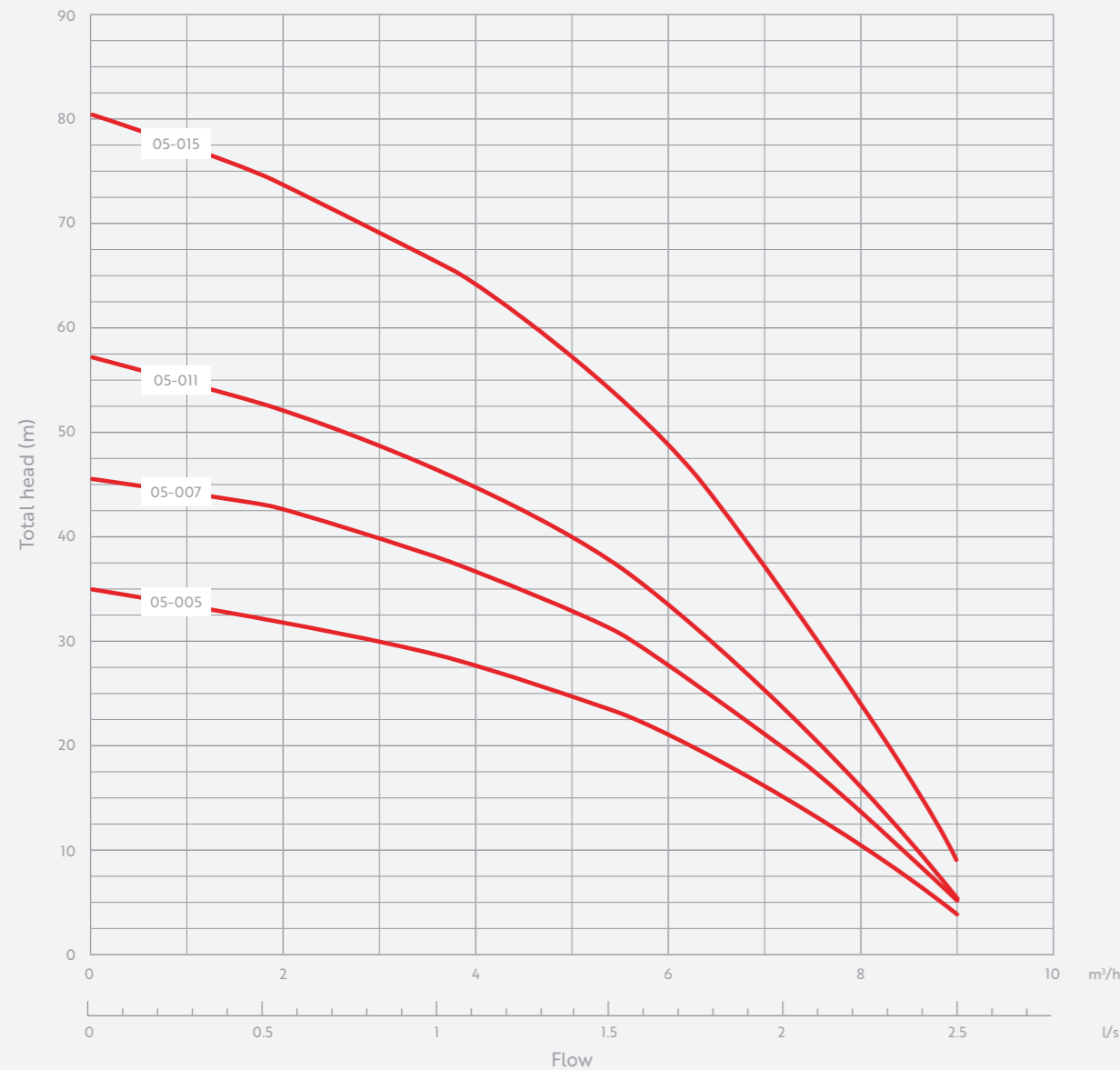

Which Category 5 Booster Set?

Whether you need a certain level of efficiency or have limited plant room space, our category 5 booster range is equipped to meet your project's requirements.

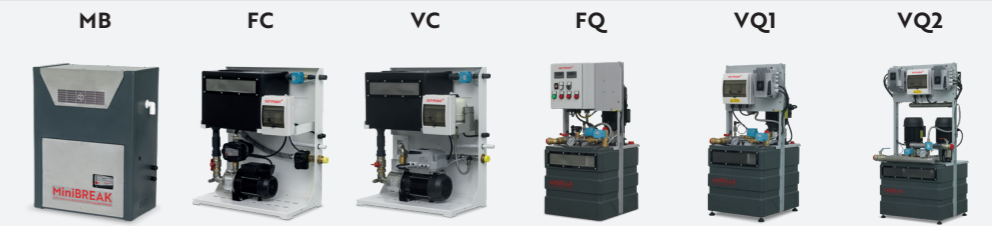

	MB	FC	VC	FQ	VQ1	VQ2
Recommended unit	MiniBREAK	AirBREAK FC	AirBREAK VC	AirBREAK FQ	AirBREAK VQ1	AirBREAK VQ2
Flow range (l/s)	0.1 – 0.4	0.2 - 1.8	0.2 - 1.8	0 - 2.2	0 - 2.2	0 - 4
Dry run protection	Yes	Yes	Yes	Yes	Yes	Yes
Pressure range (bar)	1 - 3	1 - 8	1 - 8	1 - 10	1 - 16	1 - 16
Nominal tank capacity (L)	23	36	36	90	90	120
Supply voltage	1ph	1ph	1ph	1ph or 3ph	1ph or 3ph	1ph or 3ph
Control type	Fixed speed	Fixed speed	Variable speed	Fixed speed	Variable speed	Variable speed
Overall dimensions (W x D x H mm)	500 x 280 x 660	650 x 389 x 798	650 x 389 x 798	450 x 520 x 1025	450 x 520 x 1025	600 x 542 x 1316
Insulated tank	Yes, optional for FQ, VQ1 and VQ2 models	Optional	Optional	Optional	Optional	Optional
Wall mountable	Yes	Optional	Optional	No	No	No
Auto vessel purge	No	No	No	Yes	Yes	Yes
Anti-seize	No	Yes	Yes	Yes	Yes	Yes
Volt-free contact	Yes	Yes	Yes	Yes	Yes	Yes
Frost protection kit available	Yes	Yes	Yes	Yes	Yes	Yes



**Let's talk about the
AirBREAK VC cat 5 booster set**

01452 300110

ENQUIRIES@DUTYPOINT.COM

DUTYPOINT.COM