



ELEMENT

by Dutypoint



Ultra High Performance Hot Water Cylinders Operation and Maintenance Manual

Document Reference: DOC-EUHPCOM2201

Table of Contents

1.Introduction	3
2.Models and Performance	4
3.Installation Instructions	6
4.Discharge Pipework	14
5.Commissioning.....	16
6. Automatic Expansion	19
7.Servicing and Maintenance	20
8.Troubleshooting and Warranty	22



1. Introduction

Element by Dutypoint unvented cylinders have been designed for use with conventional heat sources requiring a storage and heating vessel (please ensure compatibility prior to installation).

The indirect heat exchanger surfaces (on indirect models) are designed to provide a rapid heat up time. The unit comes complete with all the necessary safety equipment to comply with legislation governing the installation of such systems.

The Element by Dutypoint unvented water heater is a high quality stainless steel unvented cylinder which can provide hot water from a cold mains water supply of between 1.5 bar and 16 bar.

1.1 The Law and Unvented Cylinders

It is legal to fit an unvented unit into any property. There is no longer a requirement to have a 'tank in the roof' system.

1.2 The Benefits of Element by Dutypoint Unvented UHP Cylinders

- Operating pressures up to 6.0 bar (dependent on model)
- High flow rate - suitable for multiple simultaneous demands
- No roof tanks required
- Can be sited wherever convenient

1.3 Standard Equipment

Check that all the components of your Element by Dutypoint Unvented UHP Cylinder are included in your package prior to installation. The package should include:

- Temperature and pressure relief valve (factory-fitted)
- Combination inlet control valve
- Expansion relief valve
- Pressure reducing valve
- 3kW heating element, incorporating control thermostat and resettable safety cut-out
- Combination (control valve comprising:
 - Tundish - 15mm female x 22mm female
 - Cylinder thermostat - temperature control setting 30-70°C
 - Thermal cut-out set to operate at 82°C ±5°C
- Expansion vessel
- Motorised zone valve

2. Models and Performance

This section contains details on the different models in the Element UHP Cylinder range, with their relative specifications and performance.

2.1 General Technical Specification

This table shows specifications which apply to every model in the Element UHP range

Description	Value
Maximum Flow Rate	77 litres/minute
Inlet/outlet Connections	28mm
Immersion Heater Voltage	240V
Immersion Heater Power	3kW (6kW option available)
Insulation Thickness	60mm
Pressure Relief Valve Setting (4.5 bar models)	6 bar
Pressure Relief Valve Setting (6 bar models)	8 bar

Figure 2.1: Identifying Models

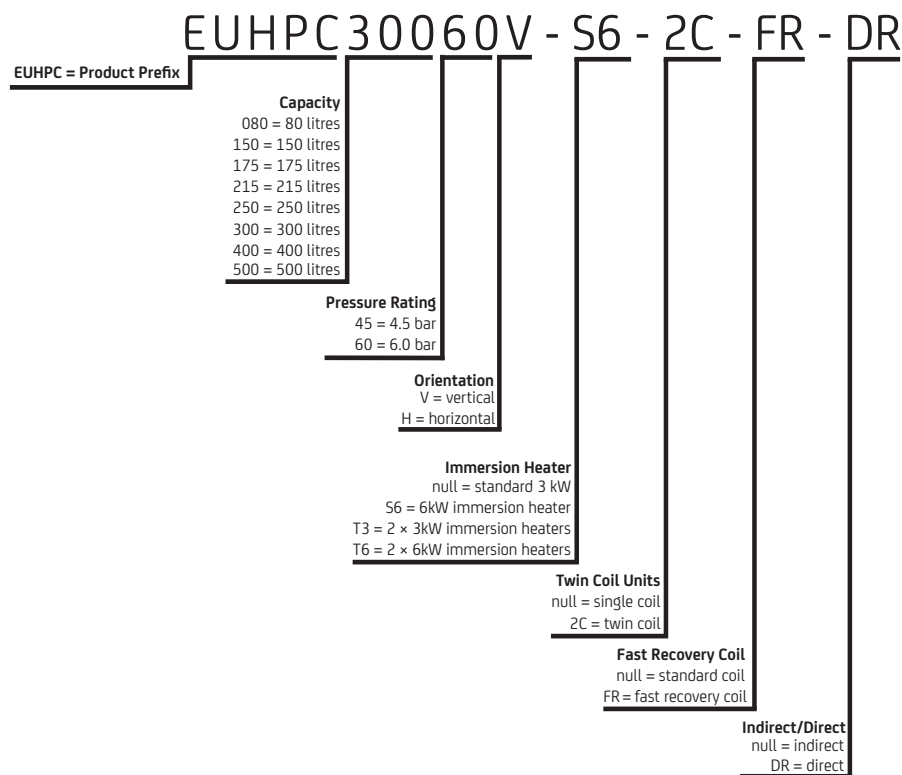

2.2 Model Specifications

All dimensions are in mm unless otherwise stated (tolerance +/- 10mm). All unvented installations must comply with the following building regulations:

- England & Wales: G3 Building Regulations
- Scotland: Technical Standard P3
- Northern Ireland: Building Regulation P5

Table 2.1: Product Codes and Specifications

Model	Capacity (litres)		Pressure (bar)	Dims (mm)		Weight (kg)		Coil (kW)	Reheat Time (mins)
	Cyl.	Vessel		Dia.	H	Dry	Full		
Vertical									
EUHPC08045V	80	12	4.5	576	665	25	105	3	17
EUHPC08060V	80	12	6	576	665	25	105	3	17
EUHPC15045V	150	24	4.5	576	1085	40	190	14	31
EUHPC15060V	150	24	6	576	1085	40	190	14	31
EUHPC17545V	175	24	4.5	576	1242	45	220	20	26
EUHPC17560V	175	35	6	576	1242	45	220	20	26
EUHPC21545V	215	35	4.5	576	1484	50	265	20	32
EUHPC21560V	215	35	6	576	1484	50	265	20	32
EUHPC25045V	250	35	4.5	576	1752	55	310	20	38
EUHPC25060V	250	50	6	576	1752	55	310	20	38
EUHPC30045V	300	50	4.5	576	2028	60	365	20	45
EUHPC30060V	300	50	6	576	2028	60	365	20	45
EUHPC40045V	400	80	4.5	756	1405	85	485	27	39
EUHPC40060V	400	80	6	756	1405	85	485	27	39
EUHPC50045V	500	100	4.5	756	1690	105	605	27	48
EUHPC50060V	500	100	6	756	1690	105	605	27	48
Horizontal									
EUHPC15045H	150	24	4.5	1085	576	40	190	14	31
EUHPC15060H	150	24	6	1085	576	40	190	14	31
EUHPC17545H	175	24	4.5	1242	576	45	220	20	26
EUHPC17560H	175	35	6	1242	576	45	220	20	26
EUHPC21545H	215	35	4.5	1484	576	50	265	20	32
EUHPC21560H	215	35	6	1484	576	50	265	20	32
EUHPC25045H	250	35	4.5	1752	576	55	310	20	38
EUHPC25060H	250	50	6	1752	576	55	310	20	38
EUHPC30045H	300	50	4.5	2028	576	60	365	20	45
EUHPC30060H	300	50	6	2028	576	60	365	20	45

*Re-heat time based on 70% draw-off at 65°C, cold water at 10°C

3. Installation Instructions

WARNING: UNDER NO CIRCUMSTANCES MUST THE FACTORY FITTED TEMPERATURE PRESSURE RELIEF VALVE BE REMOVED. THIS WILL INVALIDATE ANY GUARANTEE OR CLAIM. THE COLD-WATER INLET VALVE ASSEMBLY MUST BE FITTED OR THE UNIT WILL NOT PERFORM SATISFACTORILY. THIS WILL INVALIDATE ANY GUARANTEE OR CLAIM.

- The cold water inlet valve assembly must be fitted or the unit will not perform satisfactorily.
 - Do not attempt to vent the primary circuit through the unit
 - All external heat sources should be installed to manufacturer's instructions and the primary circuit through the unit must be pumped.
-

3.1 Benchmark Scheme Checklist

Benchmark places responsibilities on both manufacturers and installers. The purpose is to ensure that customers are provided with the correct equipment for their needs, that it is installed, commissioned and serviced in accordance with the manufacturer's instructions by competent persons. The Benchmark Code of Practice is available from the Heating and Hot Water Industry Council, who manage and promote the scheme. Visit www.centralheating.co.uk for more information.

Please ensure that the installer has fully completed the Benchmark Checklist on the inside back pages of the installation instructions supplied with the product and that you have signed it to say that you have received a full and clear explanation of its operation. The installer is legally required to complete a commissioning checklist as a means of complying with the appropriate Building Regulations (England and Wales).

All installations must be notified to Local Area Building Control either directly or through a Competent Persons Scheme. A Building Regulations Compliance Certificate will then be issued to the customer who should, on receipt, write the Notification Number on the Benchmark Checklist.

3.2 Positioning the Unit

NOTE: Element UHP Cylinders are designed for indoor use only.

The unit can be placed anywhere convenient. Since it is connected directly to the mains water supply it is equally efficient on any floor – ground, first or second. Avoid areas that may be subject to frost. Try to keep pipe runs as short as possible for maximum economy, especially hot water discharge pipes running down from the unit.

The unit can be fitted into a conventional airing cupboard and does not require any additional insulation.

The water supply to the cylinder should be potable water direct from a public mains supply with any water treatment equipment functioning correctly.

3.3 Vertical Cylinders

If installing a vertical cylinder, ensure it is fixed securely in an upright position for correct operation.

3.4 Horizontal Cylinders

If installing a horizontal cylinder, ensure it is fixed securely with the temperature and pressure relief valve positioned at the top for correct operation.

3.5 Storage and Handling

If the cylinder is not being installed immediately, it should remain in its protective wrapping with all pipe end protective caps in place to prevent damage.

3.6 Cold Water Valve

The combined cold water valve (supplied) can be connected anywhere on the cold water mains prior to the unit. It can be located at a point near to where the mains supply enters the premises if this is more convenient. When installing the cold water valve, ensure that the arrow is pointing in the same direction as the mains water supply flow when connecting (see figures 5 and 6).

The cold water balancing port, on the valve, allows you to connect the cold water mains to the rest of the property thus giving balanced pressure throughout. If this facility is not required leave the cap on.

3.7 Check Water Pressure and Flow Rates

Dutypoint suggests 1.5 bar pressure and 20 litres/minute flow rate to be the minimum requirements for satisfactory operation. The unit will still operate below this, but it will not be possible to run two or more outlets at the same time.

3.8 Drain Tap

A drain tap to drain the unit must be fitted to the cold-water inlet pipe between the cylinder and the cold water valve assembly at its lowest level possible (see [Figure 3.2: Secondary Return Connection Installation](#) (p. 10), [Figure 3.3: Installation Schematic - External Expansion](#) (p. 11) and [Figure 3.4: Combination Inlet Valve](#) (p. 11)).

3.9 Pipework to Outlets

Pipework to outlets should be suitably sized to meet appliance requirements.

3.10 Inlet Group

The inlet group will vary depending on whether the vessel is fitted as internal or external expansion (see [Figure 3.2: Secondary Return Connection Installation](#) (p. 10), [Figure 3.3: Installation Schematic - External Expansion](#) (p. 11), [Figure 3.4: Combination Inlet Valve](#) (p. 11)).

3.11 Connecting the Water Supply

Pipework is not supplied. All pipework should be installed using good plumbing practice. We recommend 22mm mains cold water supply is used. Install a stop cock valve before the cold water inlet assembly on the incoming mains water supply so the unit can be isolated if required.

3.12 Primary Circuit

The motorised valve supplied and the thermal cut-out (high limit stat) must be fitted to the primary flow (use compression fittings only).

3.13 Operation of the cut-out & motorised valve

To comply with regulations and to prevent the temperature reaching 100°C the thermal cut-out supplied must be fitted.

The thermal cut-out is wired in series to the cylinder thermostat. When the thermal cut-out senses an abnormal rise in temperature in the primary flow the electrical supply to the motorised valve will be cut and the valve will return to the closed position. This will cut-off the primary water from the boiler to the indirect

coil in the cylinder. If the thermal cut-out operates it must be reset manually. Check the cylinder stat and/or boiler stat.

PRODUCT IS NOT SUITABLE FOR SOLID FUEL OR WOOD BURNING BOILERS

- These systems must not be used on the primary circuit of an unvented hot water system.
-

PRODUCT IS NOT SUITABLE FOR GRAVITY CIRCULATION SYSTEMS

- The primary circuit must be pumped.
-

DO NOT REMOVE OR ADJUST THE TEMPERATURE AND PRESSURE RELIEF VALVE

- The valve is pre-calibrated to open at 6 or 8 bar, and at 90°C
 - Any attempt to adjust it will invalidate warranty and may affect the safety performance of the unit.
-

3.14 Secondary Return (where applicable)

Some Element cylinders are fitted with a secondary return connection. Secondary circuit connections must be made to the cylinder in accordance with the recommended installation diagram. A drain cock (not supplied) should be fitted in the cold water inlet to facilitate draining of the cylinder (see Figure 3.2). A swept tee* is needed for all indirect models if secondary circulation is required and is fitted as per the illustration. A non-return valve* must also be fitted to prevent back flow. A pump* will be required to circulate the hot water. The return feed is in 15mm pipe and all work can be done on site. *not supplied.

IMPORTANT: IF A SECONDARY CIRCULATION CIRCUIT IS INSTALLED THEN A LARGER EXPANSION VESSEL MAY BE REQUIRED TO HANDLE THE INCREASE IN WATER VOLUME.

- Calculate the additional water volume;
 - Contact Dutypoint Service on 01452 300590 regarding suitable vessel sizes.
-

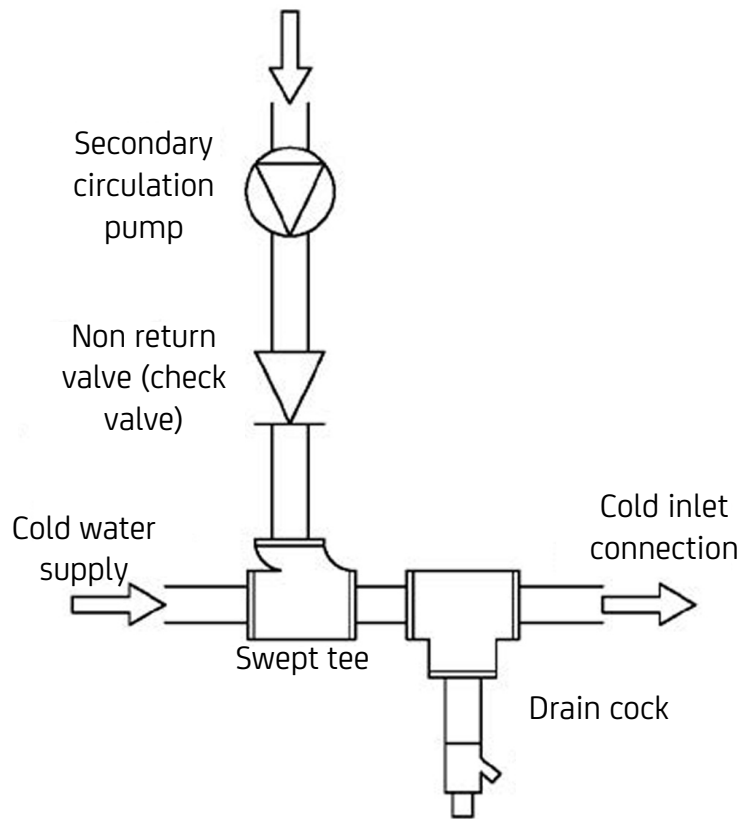
Figure 3.2: Secondary Return Connection Installation

NOTE: This arrangement shows the recommended installation where there is not a specified secondary return connection. The majority of units in the Element range do have a 1/2" secondary return connection that should be used instead.

3.15 External Expansion Vessel

This smaller tank is connected to the cold-water inlet side of the vessel. Mount the tank according to separate manufacturer's instructions provided with the external expansion vessel.

A suitable expansion vessel is supplied with Element cylinders with external expansion. Pre-charge the expansion vessel to match the pressure reducing valve (PRV) pressure setting. If kept at factory setting, 4.5 bar models should be pre-charged to 4.5 bar and 6.0 bar models should be pre-charged to 6.0 bar.

The expansion vessel should be tee'd off between the pressure relief valve and the cylinder (see figure 3.3) and should always be positioned with the entry point at the bottom. Installation should always be by means of a standard T connector ensuring no other valve is between this and the cylinder. Ensure that the expansion vessel is pre-charged to match the pressure relief valve (PRV) pressure setting.

3.16 Recommended Installation Schematics

Figure 3.3: Installation Schematic - External Expansion

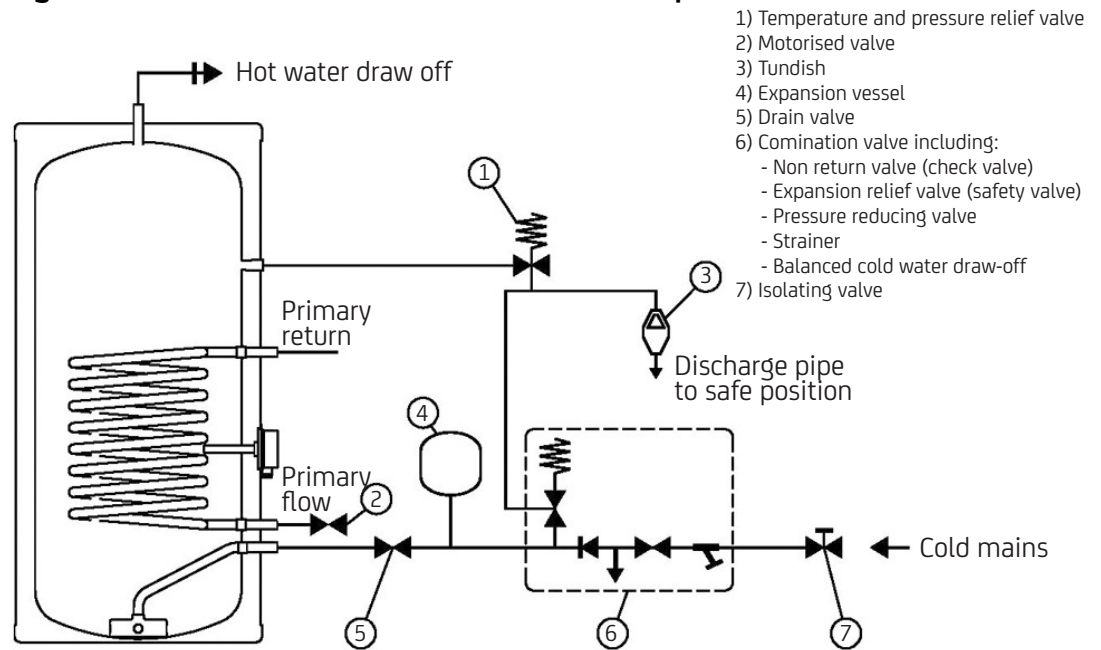
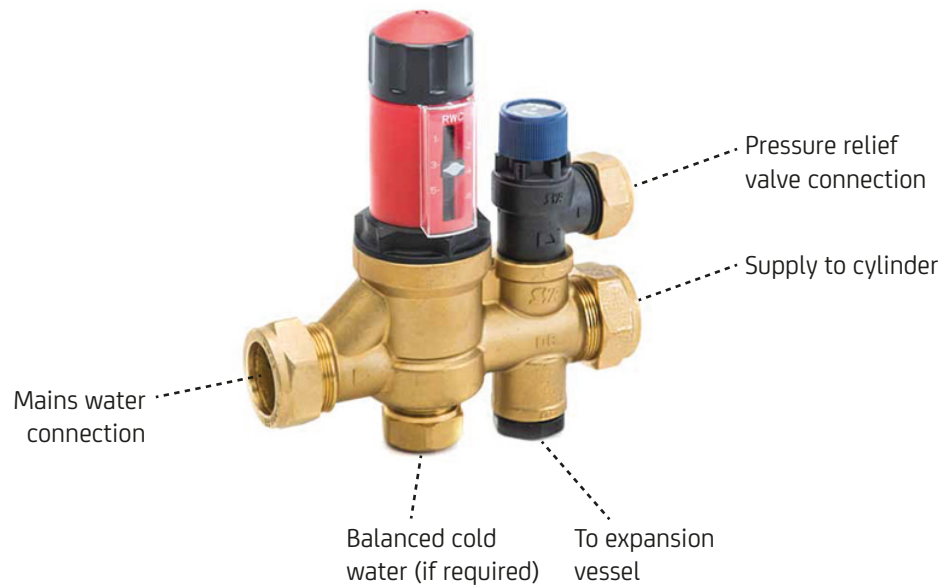

Figure 3.4: Combination Inlet Valve



3.17 Wiring Instructions

WARNING: ALL ELECTRICAL WIRING SHOULD BE CARRIED OUT BY A COMPETENT ELECTRICAL CONTRACTOR AND MUST CONFORM TO THE LATEST IEE WIRING REGULATIONS

- Do not switch the power on until the unit has been filled with water and all wiring has been earthed.

Figure 3.5: S Plan Wiring Diagram

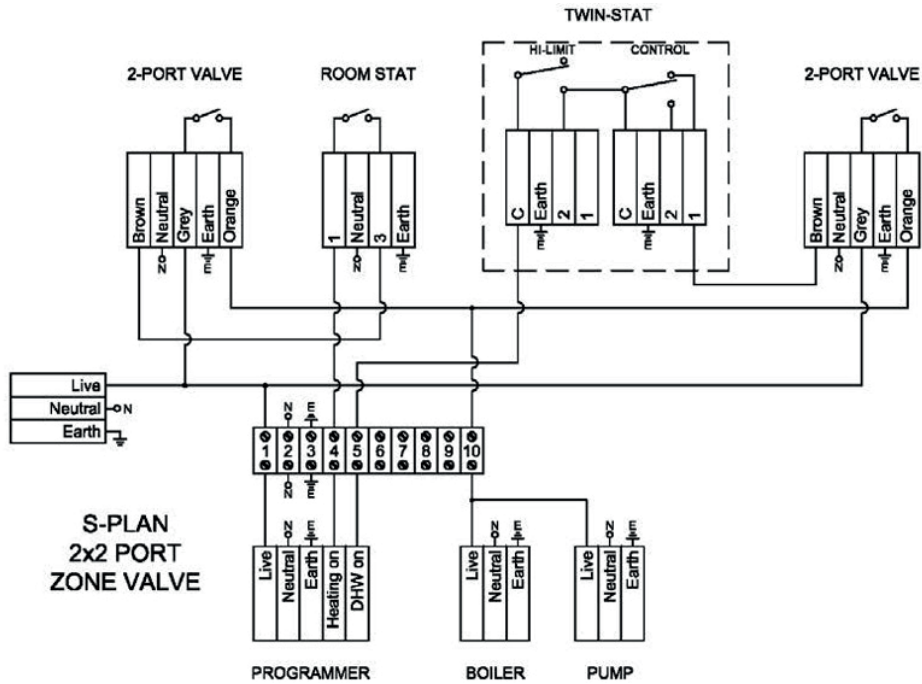
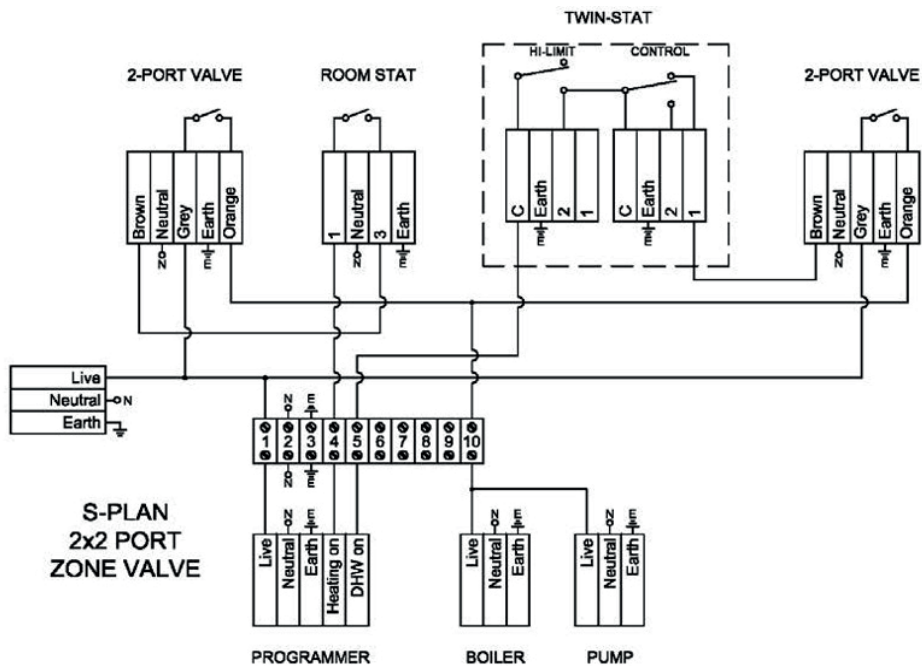

Figure 3.6: Y Plan Wiring Diagram



3.18 Immersion Heater

Secondary circuit connections MUST be made to the cylinder in accordance with the recommended installation diagram. A drain cock should be fitted in the cold water inlet to facilitate draining of the cylinder. Not supplied.

NOTE: ANY IMMERSION HEATERS THAT ARE 6KW OR GREATER MUST BE WIRED THROUGH A CONTACTOR ON SITE. SPEAK TO A QUALIFIED ELECTRICIAN IF YOU ARE UNSURE - FURTHER DETAILS AVAILABLE ON REQUEST IF REQUIRED.

IMPORTANT: ENSURE THAT THE IMMERSION HEATER THERMOSTAT IS SET TO A MAXIMUM OF 60°C.

Figure 3.7: Immersion Heater Connections and Control Thermostat Settings

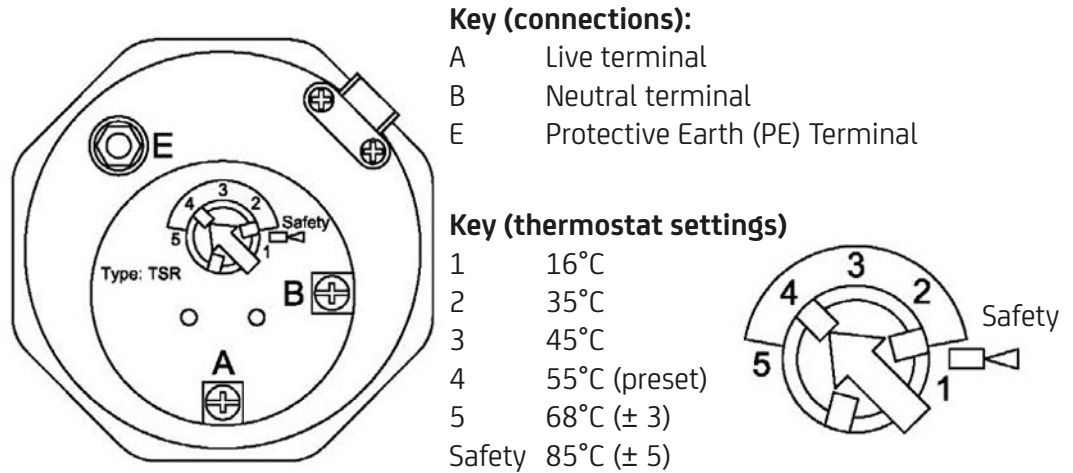

3.19 Fitting the Twin Thermostat

Figure 3.8: Cylinder Thermostat and Thermal Cut-Out Connections

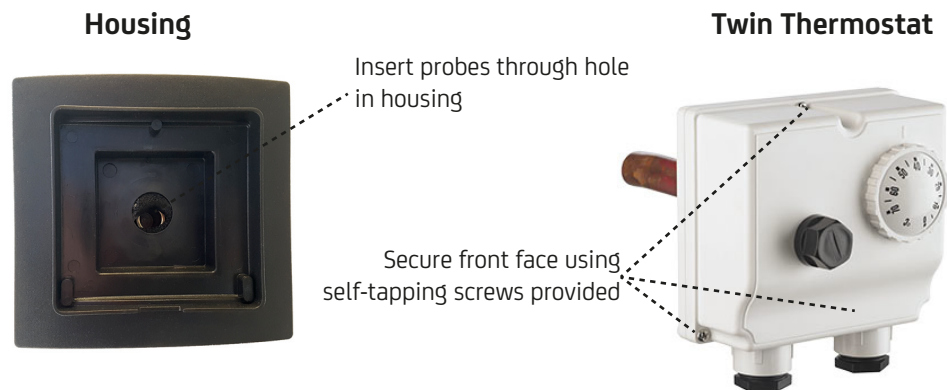

3.20 Tundish

The tundish supplied must be fitted so it is visible to the occupier. The discharge pipe must be 22mm copper pipe. Regulations do not permit more than 3 x 90-degree bends between the cylinder and the outflow. Between the temperature & pressure relief valve and the first 90-degree bend there must be a fall of at least 300mm. The fall of the pipework must be continuous and the pipe should terminate in the gully or be bent backwards onto an outside wall, in a place where discharge cannot be injurious to persons.

Figure 3.9: Tundish Installation

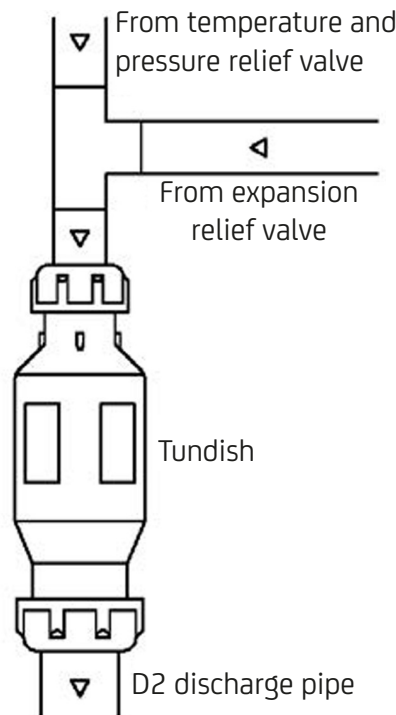

IMPORTANT: EXPANSION VESSEL MUST BE CHECKED REGULARLY

- Perform regular checks to ensure the expansion vessel is always correctly pressurised to match the pressure reducing valve (PRV) setting. The factory settings are 4.5 bar (4.5 bar models) or 6.0 bar (6.0 bar models).

Figure 3.91: Solar Twin coil version

SCHEDULE OF MATERIALS

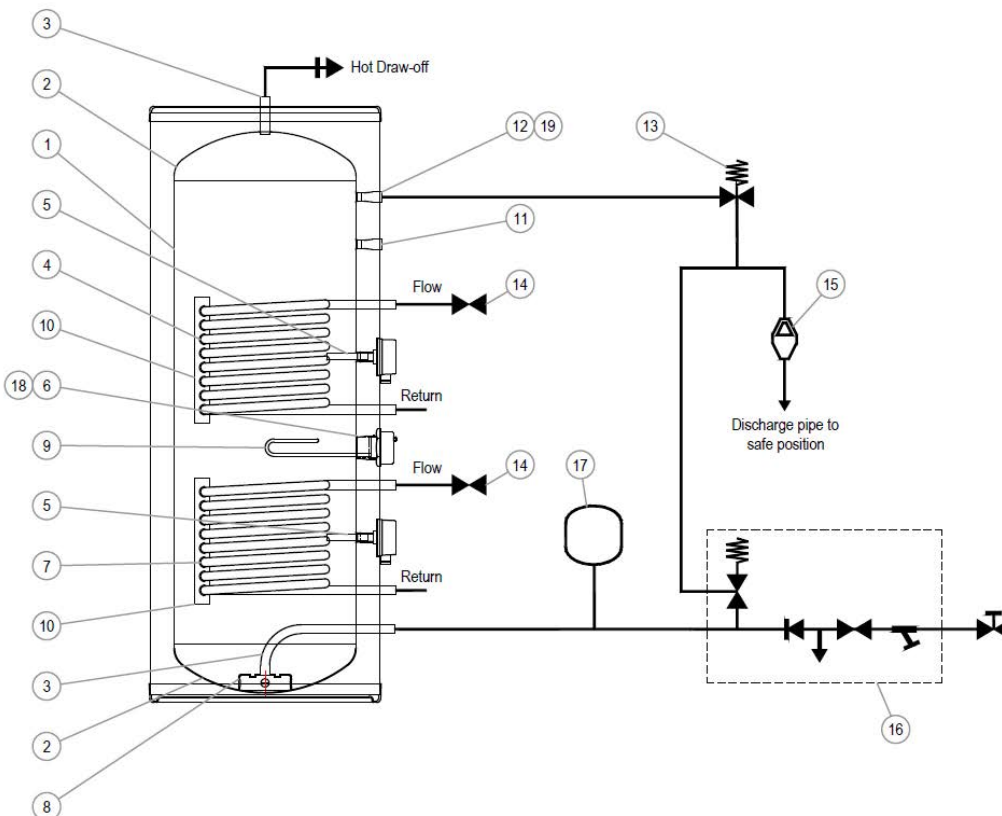

- 1 - Inner vessel - wrapper
- 2 - Dished end - upper & lower
- 3 - Inlet / outlet pipe
- 4 - Corrugated coil (upper)
- 5 - Thermostat pocket
- 6 - Immersion heater boss
- 7 - Corrugated coil (lower)
- 8 - Inlet baffle
- 9 - Immersion heater
- 10 - Coil support / spacer
- 11 - Secondary return / sensor pocket boss
- 12 - Temperature / pressure relief valve boss
- 13 - Temperature / pressure relief valve
- 1/2" valve includes integral PTFE paste
- 3/4" valve used in conjunction PTFE tape (item 19)
- 14 - Motorised valve
- 15 - Tundish
- 16 - Combination valve
- 17 - Expansion vessel
- 18 - O-ring (immersion heater)
- 19 - PTFE tape (T&P valve)

VESSEL VOLUME (litres)	MODEL NUMBER	DIAMETER	HEIGHT
130	WS-0130-C2	576mm	957mm
150	WS-0150-C2	576mm	1085mm
175	WS-0175-C2	576mm	1242mm
215	WS-0215-C2	576mm	1484mm
255	WS-0255-C2	576mm	1752mm
305	WS-0305-C2	576mm	2028mm
400	WS-0400-C2	756mm	1405mm
500	WS-0500-C2	756mm	1690mm

4. Discharge Pipework

4.1 G3 Requirement

'...there shall be precautions...to ensure that the hot water discharged from safety devices is safely conveyed to where it is visible but will not cause danger to persons in or about the building.'

4.2 G3 Guidance

The discharge pipe (D1) from the vessel up to and including tundish is generally supplied by the manufacturer of the hot water storage system. Where otherwise the installation should include the discharge pipe(s) (D1) from the safety device(s). In either case the tundish should be vertical, located in the same space as the unvented hot water storage system and be fitted as close as possible to, and lower than, the safety device, with no more than 600mm of pipe between the valve outlet and the tundish.

4.3 The discharge pipe (D2)

The discharge pipe (D2) from the tundish should:

- Have a vertical section of pipe at least 300mm long below the tundish before any elbows or bends in the pipework (see Figure13).
- Be installed with a continuous fall of at least 1 in 200 thereafter.

The discharge pipe (D2) should be made of metal or other material that has been demonstrated to be capable of safely withstanding temperatures of the water discharged and is clearly and permanently marked to identify the product and performance standard (e.g. as specified in the relevant part of BS 7291-1:2006 Thermostatic pipes and fittings for hot and cold water for domestic purposes and heating installations in buildings, General Requirements).

4.4 Termination of discharge pipe

The discharge pipe (D2) from the tundish should terminate in a safe place where there is no risk to persons in the vicinity of the discharge.

Examples of acceptable discharge arrangements are:

- To a trapped gully with the end of the pipe below a fixed grating and above the water seal.
- Downward discharges at low level; i.e. up to 100mm above external surfaces such as car parks, hard standings, grassed areas etc. are acceptable providing that a wire cage or similar guard is positioned to prevent contact, whilst maintaining visibility.
- Discharges at high level: e.g. into a metal hopper and metal downpipe with the end of the discharge pipe clearly visible or onto a roof capable of withstanding high temperature discharges of water and 3m from any plastic guttering system that would collect such discharges.
- The discharge would consist of high temperature water and steam. Asphalt, roofing felt and non-metallic rainwater goods may be damaged by such discharges

4.5 Worked Example of Discharge Pipe Sizing

The example below is for a G1/2 temperature relief valve with a discharge pipe (D2) having 4 No elbows and length of 7m from the tundish to the point of discharge. From table 1

Maximum resistance allowed for a straight length of 22mm copper discharge pipe (D2) from G1/2 temperature relief valve is 9m. Subtract the resistance for 4 No 22mm elbows at 0.8m each = 3.2m, therefore the permitted length equates to 5.8m. This is less than the actual length of 7m therefore calculate the next largest size.

Maximum resistance allowed for a straight length of 28mm pipe (D2) from a G1/2 temperature relief valve equates to 18m Subtract the resistance of 4 No 28mm elbows at 1m each = 4m.

Therefore the maximum permitted length equates to 14m. As the actual length is 7m a 28mm (D2) copper pipe will be satisfactory.

Figure 4.10: Typical Discharge Pipework Arrangement

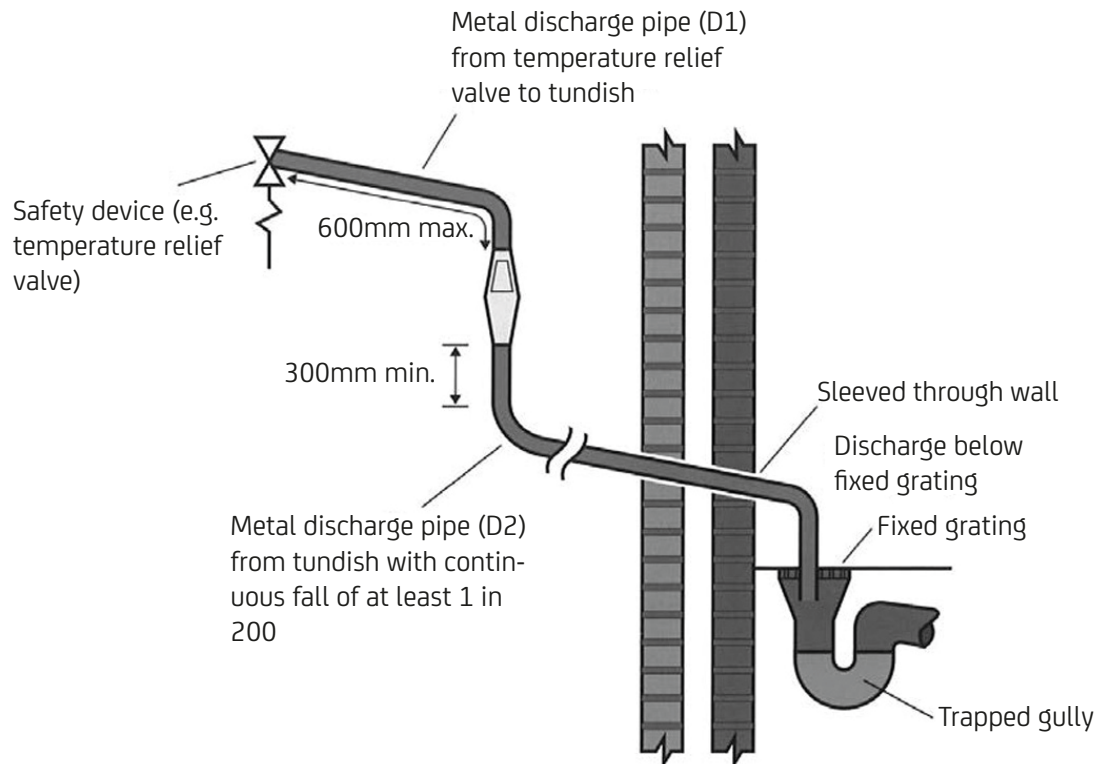

IMPORTANT: THE DISCHARGE WILL CONSIST OF SCALDING WATER AND STEAM. ASPHALT, ROOFING FELT AND NON-METALLIC RAINWATER GOODS MAY BE DAMAGED BY SUCH DISCHARGES

- Take necessary precautions

5. Commissioning

- 1) Before turning on the mains supply to the cylinder, a hot water tap should be opened, preferably on the same floor or the floor below the location of the cylinder.
- 2) Turn on the supply to the cylinder and fill until water runs from the open hot water tap.
- 3) Close the hot water taps and bring the cylinder up to working pressure.
- 4) Complete Commissioning Report below.

5.1 Commissioning Report

NOTE: The Commissioning Report should be completed by a competent person who has commissioned the system as a means of demonstrating compliance with the appropriate building regulations and then handed to the end user to keep for future reference.

Client Details		Site Details	
Contact Name		Contact Name	
Address		Address	
Telephone		Telephone	

Product Details			
Model		Serial Number	
Capacity		Location	
Vertical/Horizontal			

All Systems Primary Settings (Indirect Heating Only)		
Is the primary circuit a sealed or open vented system?	Sealed	
	Open	
Maximum primary flow temperature		°C

System Performance (All Systems)		
Incoming cold water pressure at the system inlet		bar
Hot water thermostat setting		°C
Maximum hot water flow rate at the set thermostat temperature (measured at high flow outlet)		l/min
Type of control system (Y/S/Other)		
Solar or renewable cylinder (✓)		
Hot water temperature at the nearest outlet		°C

Standard Checks - All Systems		✓
Strainer cleared of debris (where fitted)		
Is the installation in a hard water area?		
If yes, water scale reducer been fitted?		
Time and temperature controls have been fitted in compliance with Part L of the Building Regulations		

Standard Checks - All Systems		✓
All appropriate pipes have been insulated up to 1 metre or the point of where they have been concealed		

System Data	
Where is the PRV situated?	
What is the PRV setting?	
Has a combined temperature and pressure relief valve and expansion valve been fitted and discharge tested?	
The tundish and discharge pipework have been connected and terminated to Part G of the Building Regulations?	
Are all energy sources fitted with a cut out device?	
Has the expansion vessel or internal air space been checked?	
Set up following working practice	
Draining following working practice	
Pressure Vessel checked - setting	
Notes	

Final Checks		✓
Check controls are installed correctly		
The hot water system complies with appropriate Building Regulations		
The system has been installed and commissioned in accordance with the manufacturers instructions		
The system controls have been demonstrated to and understood by the customer?		
The manufacturers literature has been explained and left with the customer		

Engineer Signoff	
Engineer Name	
Date	
Arrival Time	
Departure Time	
Signature	

5.2 Draining

- 1) Switch off electrical power to the immersion heaters and/or shut down the boiler. Close the stopcock valve to isolate the unit.
- 2) Attach a hosepipe to the drain cock with sufficient length to take water to a suitable discharge point.
- 3) Open the drain cock.
- 4) Open the hot water tap nearest the unit. If water fails to drain from the cylinder, vent the system by opening the temperature and pressure relief valve.

5.3 Scale

In hard water areas lower water temperatures can result in less scale being deposited.

If a water softener is used it should be capable of flows up to 77 litres/minute and operating pressures matching the operating pressure of the cylinder (4.5 bar or 6 bar). This will maintain the performance of the unit. If no de-scaler or softener is used then the heating elements will require periodic de-scaling for maximum efficiency and to prevent damage.

5.4 User Instructions

Your Element UHP unvented hot water cylinder has been designed to give many years of trouble-free service and is made from hygienic, high grade stainless steel. A backup electric immersion heater heats the water to 60°C.

The flow temperature of the hot water can be set to your requirements on the immersion heater (ideally maximum 60°C. Higher temperatures can cause tripping of the high limit thermostat and introduce more energy loss from the cylinder.

When a hot tap is turned on there may be a short surge of water, this is quite normal with unvented systems and does not indicate a fault. When you first fill a basin the water may sometimes appear milky. This is due to very small air bubbles in the water which will clear quickly.

WARNING: IF COLD/ARM WATER EXISTS FROM THE TEMPERATURE AND PRESSURE RELIEF VALVE (TPV) OR FROM THE PRESSURE RELIEF VALVE (PRV):

- Call your installer or call Dutypoint Service on 01452 300590.
-

WARNING: IF VERY HOT WATER EXITS FROM EITHER VALVE:

- Switch off the heat source immediately
 - Isolate the electrical supply to the cylinder and separate heat source.
-

6. Automatic Expansion

For cylinders featuring our revolutionary automatic expansion technology, there are a few subtle differences to our standard designs to be aware of. This feature takes the well-known concept of internal expansion to a new level, and the key part of this is the automatic air replenishment device,

In accordance with B.S. 7206: 1990 to accommodate for the expansion of the water as it is heated inside the water tank an external pressurized expansion vessel is coupled to the tank. Over a period of time the expansion vessel will lose its charge & will have to be re-pressurized. An alternative to fitting an expansion vessel is to arrange for a volume of air to be provided above the water level inside the water heater (internal expansion). This will eliminate the need for the external expansion vessel & reduces installation time. However, with internal expansion the air is absorbed by the water. When this happens a procedure needs to be carried out to manually replace the air in the vessel, this means regular recharging.

The revolutionary new technology incorporated into the Dutypoint automatic expansion range, automatically re-charges the air gap in the vessel every time water is drawn off by the user, creating a fully automated, self-sustaining system.

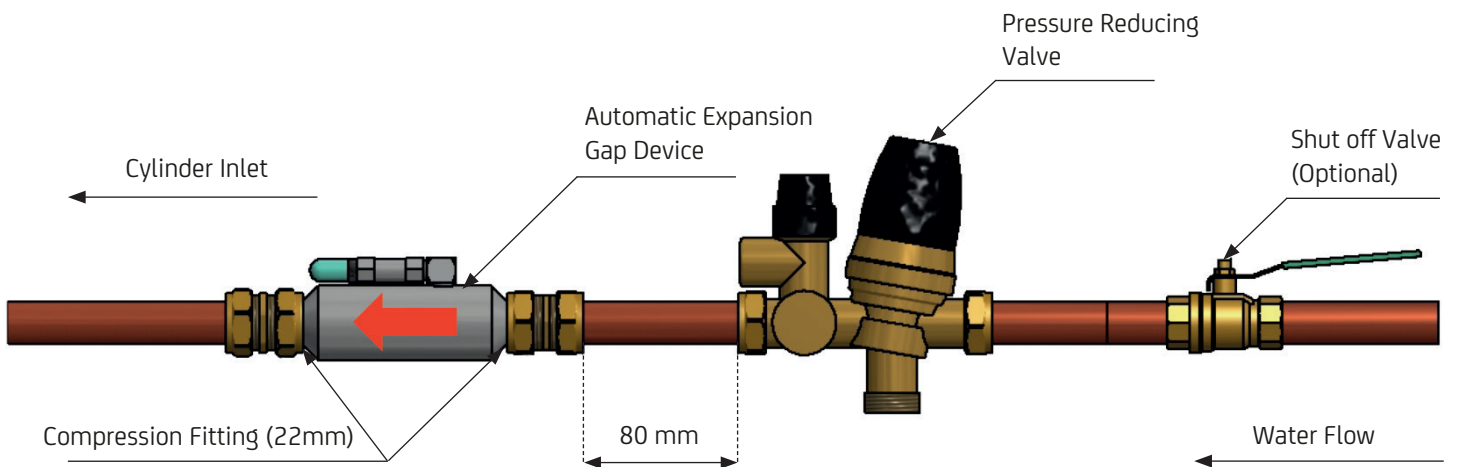

IMPORTANT: ALL WORK TO AN EXISTING OPERATING SYSTEM SHOULD BE CARRIED OUT BY A SUITABLY QUALIFIED INSTALLER

- The air gap device is fitted on the water inlet between the pressure reducing valve and the cylinder per diagram above.
- Ensure that a minimum of 80mm pipe length exists between the compression fitting on the Air Gap Device and the pressure reducing valve.
- For ease of maintenance you may wish to add in a water inlet shut off valve before the pressure reducing valve.
- The Air Gap Device can be mounted vertically or horizontally.
- We also recommend to position the device above the level of the T&P on the vessel, this will aid any future maintenance.



7. Servicing and Maintenance

Servicing and maintenance should only be carried out by a competent unvented hot water installer or Dutypoint authorised personnel.

WARNING: BOTH THE PRIMARY AND SECONDARY SYSTEMS WILL CONTAIN VERY HOT WATER THAT WILL SCALD

- Care must be taken when opening any joints, seals or valves.
 - The system must be isolated from the electricity supply.
-

WARNING: NON-GENUINE PARTS CAN BE DANGEROUS AND WILL INVALIDATE WARRANTY

- Only use spare parts authorised by Dutypoint.
-

This product should be at least annually to optimise its safety, efficiency and performance. The service engineer should complete the relevant checks and procedures as stated in 5. [Commissioning](#). Once the service is completed, the engineer should complete the service record below.

7.1 Service Record

Date	Engineer Name	Company	Remarks

Date	Engineer Name	Company	Remarks

7.2 Replacing air gap if lost during service

- 1) Turn off the mains supply to the unvented hot water cylinder
- 2) Open a hot water tap, preferably on the same floor or the floor below where the cylinder is located to relieve pressure.
- 3) Check pressure within expansion vessel. Re-pressurise to 6 bar (4.5 bar models) or 8 bar (6 bar models).
- 4) Close the hot water tap.
- 5) Turn the mains supply back on and bring the cylinder up to working pressure.

7.3 Disposal

Those responsible for installing the cylinder are responsible for disposal of any transport packaging. Observe national regulations.

You must not dispose of the cylinder or any of its accessories in normal domestic rubbish. The cylinder and accessories must be disposed of in accordance with national regulations.

Both the cylinder and transport packaging contain many recyclable parts

8. Troubleshooting and Warranty

8.1 Troubleshooting Guide

DANGER OF ELECTRIC SHOCK

- Disconnect the electrical supply before removing any electrical equipment cover.

Table 8.1: Faults, Causes and Remedies

Fault	Possible Cause	Remedy
Cylinder cools down overnight	One pipe circulation in the case of short pipe networks with low pressure loss	Install a non-return valve as close as possible to the cylinder
Primary heating is not working. Boiler runs for a short period, goes off, then comes on again. This is repeated until the cylinder reaches its target temperature	Air trapped in heat exchanger Heat exchanger surface too small	Vent air from heat exchanger circuit Check data for boiler and cylinder. The problem may be solved by increasing the flow from boiler
Intermittent water discharge through tundish on warm up	Expansion vessel has lost its charge pressure (vessels with external expansion only) Internal air gap needs replenishing	Follow steps listed in Service & maintenance section Follow steps listed in Servicing & maintenance section
Only cold or lukewarm water comes out of taps	Programmer set to heating only or not switched on for hot water Central heating boiler malfunction High limit thermostat has tripped Pump malfunction If only cold water comes out of taps, hot and cold pipes may have been connected up incorrectly	Set programmer to call for hot water on demand Check boiler operation. If faulty consult manufacturers instruction manual Check and re-set. The cause will need to be identified Check wiring and/or plumbing connections to pump Check connections and have them changed if necessary
Continuous water discharge	Pressure reducing valve (PRV) not functioning properly Expansion relief valve not seating correctly Temperature and pressure relief valve not seating correctly	Check pressure from PRV. Replace cartridge if necessary. Manually lift the valve once or twice to clear debris from the seat. If this does not cure the problem, replace the valve. Manually lift the valve once or twice to clear debris from the seat. If this does not cure the problem, replace the valve.

8.2 Warranty

Dutypoint Ltd guarantee the immersion heater and controls for a period of 1 year from date of purchase, excluding any failure caused by lime-scale, providing that they have been installed for their intended use by a competent person and have not been modified in any way.

In addition Dutypoint Ltd guarantees domestic stainless steel inner hot water cylinders for a period of 25 years from the date of purchase against faulty material or manufacture provided that:

- The vessel has been installed by a competent person in accordance with this manual and all current regulations and codes of practice in place at the time of installation.
- It has been used solely for the purpose of heating potable water that complies with current (at the time of installation) EU standards and is not fed with water from a private source.
- It had not been modified in any way.
- It has not been subjected to excessive pressure or electrolytic action from dissimilar materials, or attack from any salt deposits.
- It has been installed indoors in a frost-free environment.
- The cylinder is connected to a public water supply maintained by a local water authority.
- The online warranty registration completed within 90 days of installation. See www.dutypoint.com/warranty-register.
- The unit has been serviced annually.
- The Service Record has been filled in after each annual service.

This warranty is not transferable and does not include claims due to frost or lime scale damage.

This guarantee does not cover a procedure of flushing the system not in accordance to the WRAS guidelines pertaining to BS 6700.

Proof of purchase will be required for any claim. This guarantee does not affect your statutory rights.

Dutypoint

Dutypoint Limited
Unit A, Quedgleley West Business Park,
Hardwicke,
Gloucester
GL2 4PA
United Kingdom

T: +44(0)1452 300592

W: www.dutypoint.com