

Dutypoint[®] Systems

ElevaTANK with VG Booster Set

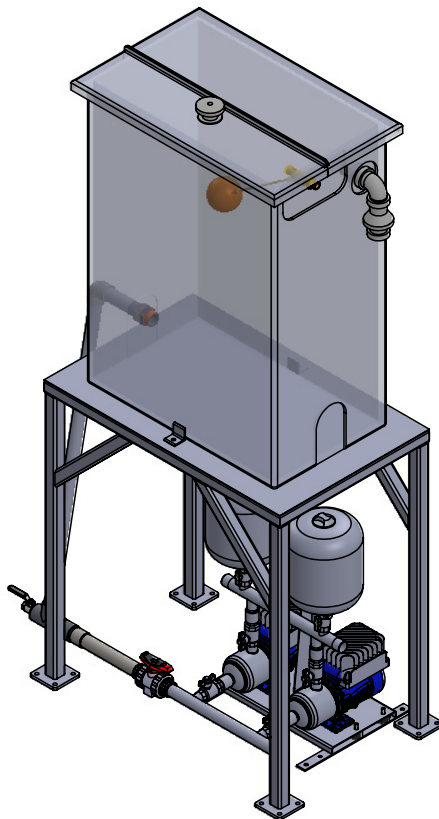

Operation and Maintenance Manual

Document Reference: DOC-ETVGOM1701

06-02-26

Table of Contents

1. Important Safety Information.....	2
2. Operating Limits.....	4
3. System Description.....	5
4. Tank Offloading and Installation.....	6
5. Commissioning.....	8
6. User Maintenance.....	12
7. Pressure Vessel.....	13
8. Lowara e-HM Pumps.....	15
9. Teknospeed Inverter.....	22
10. EC Declaration of Conformity.....	47



Unit A,
Quedgeley West
Business Park,
Gloucester
GL2 4PA
United Kingdom

T: +44(0) 1452 300110
W: www.dutypoint.com

1 Important Safety Information

1.1 Health & Safety at Work Act 1974

Section 6(a) of this Act requires manufacturers to advise their customers on the safety and the handling precautions to be observed when installing, operating, maintaining and servicing their products. The user's attention is therefore drawn to the following:

- The appropriate sections of this manual must be read before working on the equipment.
- Installation, operating and maintenance must only be carried out by suitably trained/qualified personnel.
- Normal safety precautions must be taken and appropriate procedures observed to avoid accidents.

Refer to Dutypoint for any technical advice or product information. It is the responsibility of the customer and/or the contractor:

- To ensure that anyone working on the equipment is wearing all necessary protective gear/clothing;
- Is aware of appropriate health & safety warnings and to read the information in this manual.

1.2 Mechanical Device Servicing

- Familiarise yourself with the relevant contents of this manual
- Installation, maintenance and repair work must only be carried out by trained, skilled and suitably qualified personnel.
- Disconnect or lock-out the power source to ensure that the item(s) will remain inoperative. Locking out the equipment by switching off the release mechanism or set value WILL NOT prevent accidental starting.
- Allow the item(s) to cool if over-heated.
- CLOSE the isolating valves on the suction and discharge connections of the affected item(s).
- If working on pump, VENT slowly and cautiously – Refer to the relevant section of this manual.
- DRAIN the pump(s).

1.3 Pump Hand Control Mode (Where Fitted)

In the 'HAND' position the pump(s) controlled by the switch will normally run at full speed and completely independently of any control devices, and can result in pump(s) running against a closed valve head if there is no draw. This can cause the system to be maintained at the maximum pressure produced by the pump plus any incoming pressure and additional pressure caused by water surge and can potentially damage the pump and other parts of the system.

The 'HAND' option should only be used with a competent operator in attendance, or when there is a continued demand sufficient to provide constant flow through the pumps to maintain the running pressure of the system to an acceptable level.

1.4 Electrical Safety - High Voltages

This information is especially applicable when Variable Speed Controllers (Inverters) are fitted to pumps.

When the inverter variable speed drive head is connected to the power supply the components of the power unit as well as certain components of the master control unit – are also connected to the power supply.

TOUCHING THESE COMPONENTS CAN SERIOUSLY ENDANGER LIFE!

- Before removing the frequency inverter cover, the system must be disconnected from the power supply
- After switching off the power supply wait at least 5 minutes before starting work on or in the inverter drive head - the capacitors in the intermediate circuit must be given time to discharge completely via the discharge restors.

UP TO 800V CAN BE PRESENT - IF THERE ARE FAULTS THIS CAN BE HIGHER

- All work carried out when the frequency inverter is open must be performed only by suitably qualified and properly authorised personnel.
-

THE SYSTEM MUST ONLY BE OPERATED WHEN IT HAS BEEN CORRECTLY EARTHED AND PIPES BONDED TO EARTH IN ACCORDANCE WITH IEE REGULATIONS

- When connecting external control wires care must be taken not to short circuit adjacent components. Bare cable ends which are not in use must be insulated.
-

1.5 Electronic Safety Devices

- Inverter drives contain electronic safety devices which switch off the control element in the event of a fault developing.
- A motor can also be stopped by 'mechanical blocking'
- If it is switched off electronically, the motor is disconnected from the mains voltage supply via the electronics in the inverter drive.
- Voltage fluctuation and power failures (temporary outages) can cause the motor to switch itself off.

A MOTOR WILL HAVE ZERO CURRENT BUT WILL REMAIN ENERGISED AS IT STOPS

- Take necessary precautions - the motor is not voltage-free in the circuit itself
-

REPAIR OF FAULTS CAN CAUSE ITEMS TO START UP AGAIN UNEXPECTEDLY

- Ensure the motor is isolated before commencing any work
-

HIGH VOLTAGE TESTS OF INVERTERS MAY DAMAGE THE ELECTRICAL COMPONENTS.

- Bridge before the incoming/outgoing terminals L-L2-L3 and U-V-W.
 - To avoid incorrect metering by capacitors incorporated in the electronic circuits, isolate the motor from the inverter drive head.
-

2 Operating Limits

Operating limits for standard Dutypoint pump sets

Type of pumped liquids	Water with no gas or aggressive substances
Maximum pumped liquids temperature	+23°C domestic uses (EN 60335-2-41), +40°C other purposes
Minimum pumped liquid temperature	+1°C to avoid icing
Operating ambient temperature	+5°C to 40°C for indoor installation. (CEI EN 60439-1)
Relative humidity	Max 50% at 40°C
Air impurities	The air must be clean and free of acid vapours, corrosive gases and excessive amounts of dust
Storage temperature	+5°C to 50°C
Suction conditions	Minimum positive pressure 0.1 Bar. Maximum positive pressure 0.5 Bar.

3 System Description

The Dutypoint Systems ElevaTANK with VG Booster Set comprises the following:

- GRP insulated tank with category 4 'AF' air gap
- Equilibrium float valve inlet, with access lid
- Mild steel frame incorporating interconnecting pipework from the tank to the pump set below
- Variable speed cold water pump set with stainless steel horizontal multistage pumps, anti-vibration base plate and controls

Figure 1: Key System Components Indicator

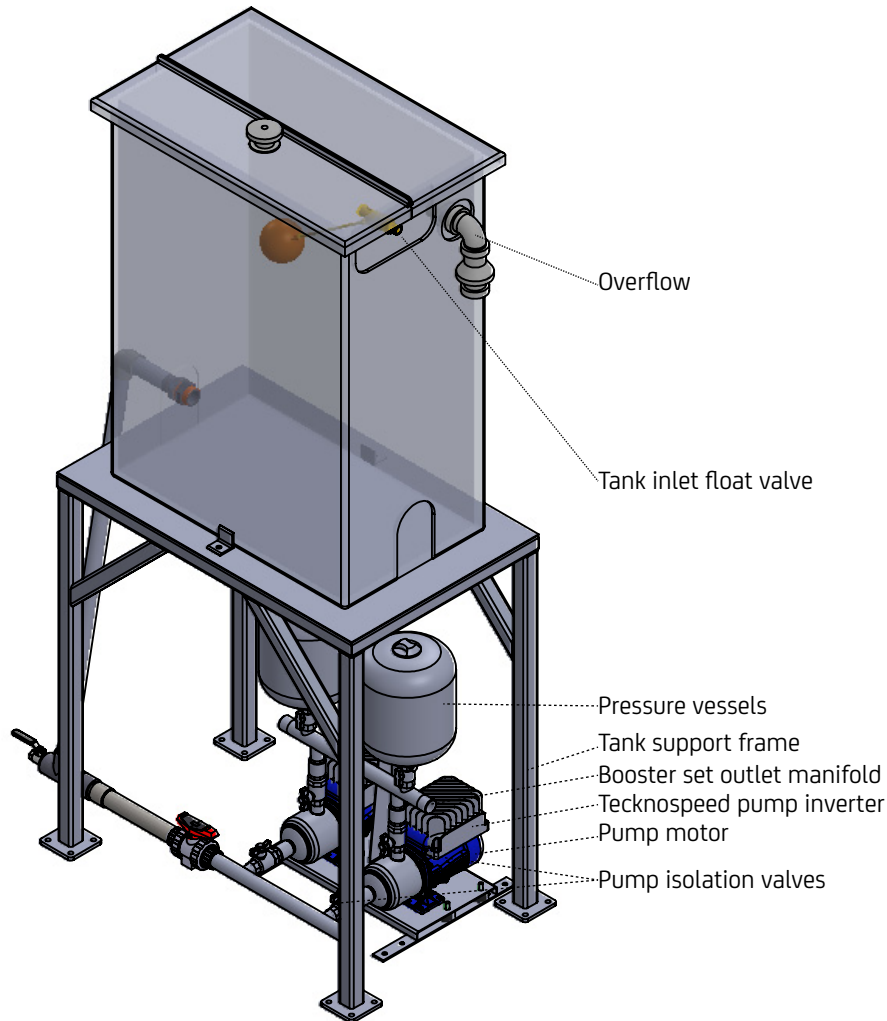
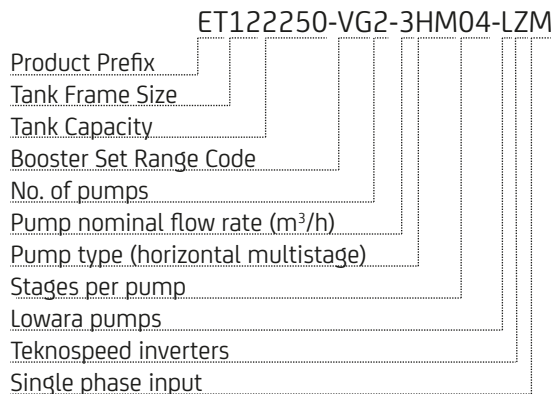

Figure 2: System Type Indicator



4 Tank Offloading and Installation

This section covers Dutypoint GRP tanks, ElevaTANK and QuadraTANK specification, offloading, installation, operation and maintenance instructions. This information applies to all clean water GRP tanks, ElevaTANK and QuadraTANK units.

4.1 Specification

GRP tank products are manufactured from non-corrosive materials to the requirements of EN 13280:2001 (formerly BS7491 Part 1 and 2) and incorporating the quality control requirements of BS EN ISO 9002:2000.

Internal surfaces in contact with the fluid are smooth isophthalic gel-coated with a high gloss finish to improve resistance to bacteriological growth. Resin is high grade orthophthalic and pigmented and shall be resistant to ultra-violet attack. The reinforced glass is to be 'E' glass type and to be long-stranded (40mm minimum). The proportion of glass shall be no less than 30% w/w.

The side walls and lid shall be manufactured with an integral expanded polyurethane foam core of 25mm, 38mm or 50mm thickness. The completed laminate shall equate to a minimum thermal conductance of 0.87, 0.55 or 0.46 w/m²°c respectively. The external finish shall be totally sealed and be sufficiently robust to withstand normal site handling and transportation.

Internal ties, if fitted, are constructed in high grade stainless steel to 1.4401. External reinforcement, if incorporated, is mild steel construction totally encapsulated and protected within the laminate.

Internal stainless steel and external MS galvanised ladders are recommended for tanks above 1.5m high, but shall only be quoted or fitted at the customers' request. All tanks and tank systems are factory water tested at manufacture stage. Standard tanks are suitable for storage of water at ambient temperature. Any other proposed applications must be notified and approved in writing.

4.2 Offloading

GRP tanks and QuadraTANKs should be unloaded and moved by fibre slings under the unit and lifting from above from a single point using a suitable crane or lifting equipment.

Dependent on the size of the tank the slings should be positioned approximately 500mm in from each end. In the case of QuadraTANKs with a pump set installed the sling positions may need to be offset to allow the unit to be level when being moved. The unit should be slightly raised from its position and it should be assessed whether or not the unit is sufficiently stable to move safely. If QuadraTANKs are more than 4 metres long, two pairs of slings or a spreader plate should be used to spread the load and reduce stress on the structure.

Lifting eyes are only to be used for lifting the unit sufficiently to allow slings to be passed under the unit. Do not use the lifting eyes to lift the unit clear of the ground.

Do not attempt to move a tank containing any water. Do not use chains to lift the unit except where they are above the lid and will not come in contact with the tank in any way.

Whilst in temporary storage on site, tanks should be placed on a level surface and care should be taken to ensure that no sharp protruding objects are present that might damage the base.

4.3 Installation

The permanent base should be level, free from any local irregularities, not vary more than 2mm in any metre and be able to support the tank throughout the complete area and be of sufficient strength to bear the weight of the tank, its water content and, in the case of a QuadraTANK, the weight of the pumping equipment without movement.

A QuadraTANK drawing should be requested prior to delivery to enable inlet/outlet ducts to be constructed in the base, positioned correctly to line up with the ducts in the QuadraTANK housing base.

It is good practice to provide a minimum 500mm clearance all around the tank to assist pipework installation. A minimum of 750mm is generally required above the tank for future tank and float valve-maintenance.

All pipework, valves etc. connected to the tank must be supported independently to reduce stress on the GRP structure.

All tanks and tank systems are factory water tested at manufacture stage. However, connections may be disturbed during transportation and should be checked for tightness before the tank is filled with water and carefully monitored once filled to ensure there is no leakage.

It is recommended that tanks should be sterilised before putting into use. Tanks should not be sterilised until they have been filled and all pipework connections have been proved to be watertight.

If secondary insulation is required it is recommended that this is not fitted until after successful commissioning of the tank.

If tanks or housings are fitted with heaters, these are normally thermostatically controlled and for frost protection only. The thermostat should be checked to ensure that it is correctly set to avoid unnecessary heating which will be a waste of energy and could impact on water quality.

4.4 Tank Annual Inspection

WARNING: THE MAIN LID FORMS PART OF THE STRUCTURE OF THE TANK

- Do not remove unless the tank is empty
-

It is recommended that water storage tanks should have an annual inspection to:

- Inspect the effectiveness and operation of the incoming float-valve and/or isolation valve arrangement.
- Inspect the cleanliness of the tank and wash out if necessary by means of opening the drain valve. Additional washing down with a hose may be necessary. QuadraTANKs will normally have a washout valve fitted on the pump set inlet pipework.
- Inspect the tank externally for any signs of dampness around its base which may be the result of leaking tank connections, condensation, damage or overflowing. Rectify as necessary.
- Inspect the tank fittings to ensure that any air vents, overflows, warning pipes and filter screens are clean and unobstructed, manways and inspection hatches are secure and sealed, and any access ladders are securely fixed.
- For most installations a test of water quality should be carried out by a competent environmental hygiene technician every 12 months. If test results are unacceptable, the tank should be chlorinated to improve water quality. (Note: Where water quality is unacceptable consideration needs to be given to upstream or downstream sources of contamination).
- Check any heater thermostat settings are correctly set in line with originally installed and commissioned settings.

5 Commissioning

5.1 Installation and Commissioning Overview

Before shipment, all Dutypoint pump sets are pre-commissioned. Whilst important procedures such as venting and rotational direction checks need to be carried out on site, initial parameters including pressure settings and delay timers will be adjusted to suit the site conditions previously advised to Dutypoint.

In practice, a system can almost invariably be made to perform more efficiently if further re-commissioning is carried out on site. Please note that engineer visits by Dutypoint are priced at one visit to commission one pump set. If there are multiple units on a site, special terms can be negotiated. To arrange a commissioning visit, please call the Technical Service Help line 01452 300590. The following checks should be carried out at the initial installation before any run tests are performed.

WARNING

- Ensure that you have read and understood [Important Safety Information](#).
-

5.2 Pipework and mechanical components

- 1) Ensure that the mounting area and any associated groundwork provides adequate support for the pump set.
- 2) Ensure all supports/brackets are in place and secure.
- 3) Verify all pipe joints are sealed and tight.

5.3 Electrical

WARNING

- These checks MUST be carried out by a competent electrician.
 - Ensure that the power source is sufficient to allow the running of two (twin pump sets) or three (triple pump sets) pumps together.
-

- 1) Check the motor voltage and frequency information on all the motor nameplates and on controllers etc. correspond with that of the source power supply.
- 2) Check that all electrical connections are correctly made and secure. Pay particular attention to Earth and bonding connections.
- 3) Carry out specific checks for Earth bonding.
- 4) Carry out NICEIC certification checks as required for the installation, e.g Earth Loop Impedance, Insulation Tests, etc.
- 5) Carry out any other pre-start checks recommended by the pump manufacturer. Refer to the pump manual in the Appendix of this manual. DO NOT POWER UP AT THIS STAGE.

5.4 Low Level Float Switch Wiring (Optional)

Terminal 1 and 3 require a normally closed contact in order to allow the pump set to operate. To facilitate this the unit will be supplied with a wire loop between 1 and 2. To install a low level float switch this loop has to be removed and the float switch wired to operate as an open on fail scenario.

If 2 or more float switches are required (due to twin compartment or multiple tanks) all float switches are wired into terminals 1 and 2 in parallel.

Figure 3: Terminal Wiring

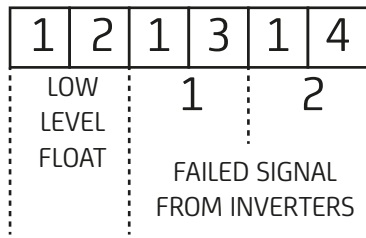

If installing a Dutypoint FS-series float switch, the following terminals should be used:

- BROWN: Terminal 1
- BLACK: Terminal 2
- BLUE: Not used - terminate safely

5.5 Final Checks Before Commissioning

- 1) Re-check all equipment for any accidental damage caused during installation.
- 2) Carry out the pre-charging and venting procedures described next.

5.6 Pressure Vessel Pre-Charging

Figure 4: Pressure Vessel Pre-charge

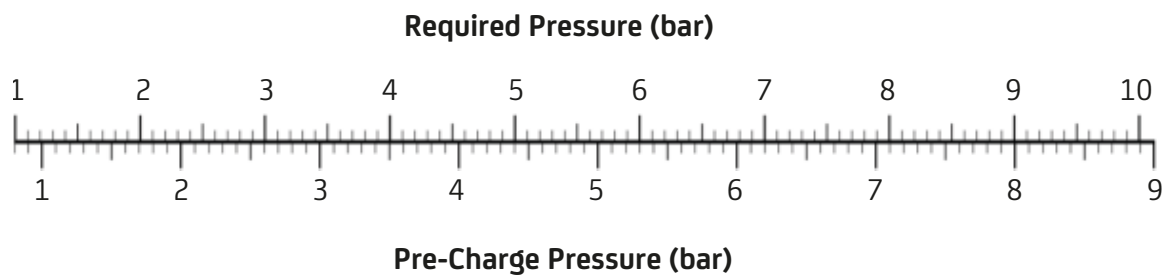

Before commissioning starts the pre-charge of the pressure vessels should be checked.

On variable speed systems the pre-charge air pressure for vessels should be 90% of the maximum pressure generated by the pump in the pipework system

e.g: If the maximum pressure generated by the pump in a system is 6 bar, this will require a pre-charge pressure of $6 \times 90\% = 5.4$ bar.

To verify the pre-charge pressure:

- 1) First check that the expansion or pressure vessel(s) are totally drained of water, and that the system is switched off and no electrical parts are live.
- 2) Locate the charging valve on each vessel, accessed by removing the plastic cover on the top of the vessel.
- 3) Connect a portable pressure gauge with a measuring range compatible with the expected pressures in your application, which has a flexible hose and Schrader-type connector to the charging valve.
- 4) Check the pre-charge pressure above the diaphragm in each pressure vessel correspond to criteria given in the text above.
- 5) If necessary, release or add additional air to correct.

5.7 Venting Pumps

It is important to bleed all air from the pump body before initial start-up.

5.8 Procedure for flooded suction

Flooded Suction is defined as the condition where there is positive pressure on the suction (inlet) side of the pump(s) as is the case where the storage tank water level is at the same or higher level than the pump bleed point.

This procedure should be carried out individually for each pump in the pump set.

- 1) Open all valves on the suction (inlet) side of the pump.
- 2) Using the vent screw at the top of the pump (refer to Appendix to locate), allow any air in the pump body and suction pipework to vent to atmosphere.
- 3) When water (under pressure from the storage tank feeding the pump on the suction side) escapes through the vent screw hole - and no more air bubbles can be seen - close the vent screw.
- 4) Switch on the electrical supply to the pump motor and start the pump in AUTO mode. As each motor starts verify that the direction of rotation correctly corresponds with the direction of the arrow shown on the body of the pump. If rotation is backward STOP, switch off the pump and investigate.
- 5) Slowly open the valve on the discharge manifold outlet to the system allowing water to be pumped into the system.
- 6) Switch off, re-close the discharge valve and repeat steps 3 to 6 several times to ensure that all air is released from the pump body and local pipework.

The above procedure should be carried out individually for each pump in the pump set.

5.9 Procedure for Lift Suction

Lift Suction is defined where the water storage tank is at a lower level than the pump set. In this case a negative pressure condition may exist at the pump suction.

WARNING: THE "LIFT SUCTION" MODE OF OPERATION REQUIRES SPECIFIC VENTING PROCEDURES.

- Please call Dutypoint Systems Technical Support on +44 (0)1452 300590 for advice before attempting to vent the pump(s).
-

The advised procedure should then be carried out individually for each pump in the pump set.

5.10 Programming the Controller

Dutypoint Systems fit a design of Inverter/Controller that is most suitable for the design duty of the pump set.

Manufacturer's information for them is detailed in the Appendices to this manual.

Carefully follow the appropriate step-by-step setting-up procedures contained in the manual, ensuring that any data required to be entered by the end user is accurately inserted where requested.

If in doubt please call Dutypoint Systems Technical Support on 01452 300590 for advice.

5.11 Operation and Performance Tests

Having checked that the pump set is installed, pre-charged, vented in accordance with the procedures set out earlier, carry out the following running tests before handing over the pump set for operational use.

- 1) Run each pump by selecting HAND (Manual) control.
- 2) Re-select to AUTO mode.
- 3) Create the conditions for a normal start and run and allow the selected 'Duty' pump to run. Whilst running observe the pressure values. Verify the pump motor speeds up / slows down in accordance with the desired control philosophy.

5.12 Duty/Standby Twin Pump Sets

- 1) On Duty/Standby sets, wait for a normal stop to take place (or create the conditions where this would happen) and check that the 'Duty' pump stops. Whilst stopped simulate a fault by inhibiting the 'Duty' pump and then recreate the conditions for a normal start to take place. Check that the 'Standby' Pump now starts and runs in place of the inhibited 'Duty' pump and observe the pressure values. Verify that the pump motor speeds up / slows down in accordance with the desired control philosophy.
- 2) Wait for a normal stop to take place (or create the conditions where this would happen) and check the 'Standby' pump stops. Whilst stopped undo the inhibit to the 'Duty' pump which should now return to normal.

5.13 Duty/Assist Twin Pump Sets

- 1) For 'Duty/Assist' applications, run the system up to pressure using the 'Duty' Pump only, then deliberately create the condition(s) which will require the 'Assist' Pump to operate as well. (e.g: open taps to reduce the pressure in the system to a point where one pump only cannot maintain the required output. Verify that the 'Assist' Pump starts and runs together with the 'Duty' Pump and that the desired pressure is duly restored and maintained.
- 2) Close the taps again (thereby reducing the demand) and check the 'Assist' Pump slows down and stops, allowing the 'Duty' Pump to continue on its own.

5.14 Commissioning/Handover Check

- 1) Record any indicated voltage / amperage / pressure data / controller passwords for future reference.
- 2) Re-check all isolating valves are fully open and replace any cover(s).
- 3) With all the isolators ON and the switches and/or control programs set to AUTO, the pump set is now fully operational in automatic control mode.

NOTE: No manual operation or attendance is required other than for routine servicing and maintenance checks. Other than for maintenance purposes, the supply to the Controller(s) and the Pump motor(s) should never be switched off.

6 User Maintenance

Routine user maintenance for Dutypoint pump sets.

Dutypoint pump sets have been designed to keep major maintenance requirements to a minimum. Planned maintenance of the pumps and other principal components should therefore be undertaken at the intervals recommended in the manuals referenced below.

It is essential that a full test following the Pre-Commissioning procedure on is carried out on an annual basis.

In addition, the operator in charge should routinely make visual checks of the equipment during use, noting particularly any unusual noises or vibrations. This will give an immediate indication of any irregularity in the operation of the system.

DANGER: DO NOT COMMENCE ANY MAINTENANCE WORK UNTIL:

- You have read [Important Safety Information](#)
 - You have the appropriate personal protective equipment
 - You have all necessary safety equipment to hand
-

Refer to the appropriate manufacturer’s information that is provided in the appendices of this manual for the equipment being serviced.

Table 1: Periodic User Checks for Pump Sets

Timing	Checks
Weekly	<ol style="list-style-type: none"> 1) Visually check the complete pump set 2) Observe the running of the pump(s) and note any unusual vibrations or sounds.
Quarterly	<ol style="list-style-type: none"> 1) Visually check the complete pump set 2) Observe the running of the pump(s) and note any unusual vibration, etc. 3) Check the cooling fan and vents on the Control Unit(s) and clear any dust or other obstructions 4) Operate each manual isolating valve three times to ensure continued efficient working
6-monthly	The pressure vessel should be drained and the pre-charge pressure checked. See Pressure Vessel Pre-Charge Instructions for more details.
12-monthly (essential)	Carry out the full pre-commissioning procedure to verify safe operation - see Commissioning .

7 Pressure Vessel

The pressure vessel supplied as part of your Dutypoint product is used to absorb and conserve the potential energy of pressurised liquid. Stored energy from liquid under pressure is transferred to the water system when required.

7.1 Installation Safety Notes

These notes are taken from the pressure vessel installation manual:

- This product is designed to hold water up to +110°C
- Never exceed the maximum working pressure and temperature of the expansion tank; ensure appropriate controls are installed for this purpose.
- During installation prepare adequate systems for drainage to limit damage caused by leakage from the tank, draining and venting.
- During installation the installer should account for external stress such as traffic, wind and earthquakes.
- Always install the appliance in conformity to current legislation.
- This product must be installed and regularly inspected by qualified personnel only.
- The manufacturer shall not be held liable for any personal or material damage caused by the product if installed and/or used improperly or in way anyhow diversely from manufacturer's specifications.
- Exceeding temperature and pressure limits specified by the manufacturer will give cause to cancel any guarantee covering the product as well as any manufacturer's liability.
- For fluids other than water, check compatibility before installing.
- The appliance must be installed in a safe place with access for authorized personnel only.
- The appliance must be protected by an appropriate earthing systems or isolated from the system by a dielectric joint.

7.2 Periodic Maintenance

Periodic maintenance is recommended at least twice a year and should be carried out by authorised specialised personnel only.

- 1) First check that the expansion or pressure tank is totally drained of water, and that the system is switched off and no electrical parts are live.
- 2) Check and, if necessary reset the pre-charge pressure, using the instruction in [Pressure Vessel Pre-Charging](#). Ensure that the pressure does not exceed the value specified in the procedure.

7.3 General Maintenance and Repair

Disconnect all electrical equipment before starting on any maintenance jobs or checking the installation pressure and temperature. The pre-charge pressure should be checked and if necessary corrected during any maintenance work.

7.4 Pressure Vessel Pre-Charge Instructions

- 1) First check that the expansion or pressure tank is totally drained of water, and that the system is switched off and no electrical parts are live.
- 2) Refer to [Pre-Charging a Pressure Vessel](#). Remove the air vent cover.
- 3) Unscrew the air valve cap.
- 4) Connect a pressure gauge. Verify that the pre-charge pressure is correct. If it is low then the vessel pre-charge must be corrected by additional inflation of the diaphragm.
- 5) When the pre-charge pressure is correct replace the air valve cap and vent cover.

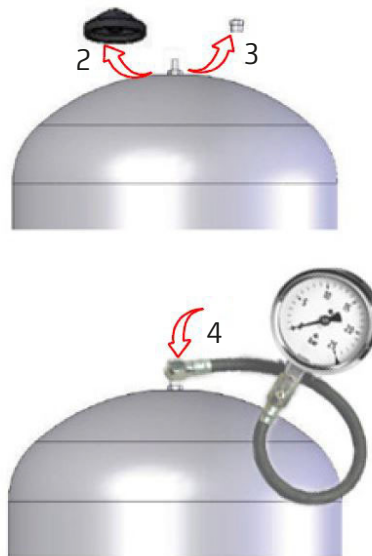
Figure 5: Pre-Charging a Pressure Vessel

7.5 Diaphragm Replacement

To replace a diaphragm:

- 1) Empty the expansion tank
- 2) Remove the pre-charging by releasing the air vent.
- 3) Loosen the M8 screws fastening the flange
- 4) Remove the flange
- 5) Extract the diaphragm and replace it

7.6 Installing a Replacement Vessel

Read these instructions carefully before installing the product:

- 1) Make sure the product is in good condition. If the product is damaged do not start on installation but take it back to the seller for immediate replacement.
- 2) The product must be installed in the position (vertical or horizontal) specified in the technical specifications.
- 3) While the system is cold, measure the static pressure with a gauge, at the point where the tank has to be installed.
- 4) Set the pre-charge pressure, using the procedure earlier in this section. Ensure that the pressure does not exceed the value specified in the procedure.
- 5) The appliance must be supplied with efficient and sufficient safety and control facilities, in particular the safety valve must be connected to the appliance and be free from interference and must be gauged to the quantity of fluid to be discharged. The safety valve should also be designed to ensure that the pressure does not permanently exceed the maximum tolerated pressure (a temporary pressure peak, limited to 10% of the maximum tolerated pressure, is allowed).
- 6) Make sure the cap of the valve is fitted tightly after pre-loading and that there is no leakage.

8 Lowara e-HM Pumps

This section provides installation, operation and maintenance details for the Lowara e-HM range of horizontal multistage pumps. The information in this section is taken from the Installation, Operation and Maintenance Manual issued by Lowara. It is provided here for additional guidance for the user.

8.1 Introduction

CAUTION: IMPROPER USE OF THE PRODUCT CAN CAUSE PERSONAL INJURY, DAMAGE TO PROPERTY AND CAN VOID WARRANTY

- Read this manual carefully before using the product
 - Ensure this manual is retained for future use
-

INEXPERIENCED USERS

- This product is intended to be operated by qualified personnel only
 - This product is not to be used by anyone with physical or mental disabilities, or anyone without the relevant experience and knowledge, unless they have received instructions on using the equipment and on the associated risks, or are supervised by a responsible person.
-

THE USE OF UNSUITABLE SPARE PARTS MAY CAUSE MALFUNCTIONS, DAMAGE, INJURIES AND MAY VOID THE WARRANTY

- Only use original spare parts to replace any worn or faulty components
 - For more information on spare parts, contact our Service department
-

8.2 Transportation and Storage

- 1) Check the outside of the packaging. If the product shows any sign of damage, inform your supplier immediately.
- 2) Remove stapled and open the carton
- 3) Remove the securing screws or straps from the base
- 4) Remove any packaging materials and dispose of according to local regulations
- 5) Inspect the product to determine if any parts have been damaged or are missing
- 6) Contact your supplier if anything is out of order.

WARNING: CRUSH HAZARD - ITEMS MAY BE HEAVY

- Observe all accident-prevention regulations in force
 - Use proper lifting methods and wear steel-toed shoes at all times
 - Check the weight that is indicated on the packaging in order to select proper lifting equipment
-

8.3 Positioning and Fastening

The unit can be transported either horizontally or vertically. Make sure that the unit is securely fastened during transportation and cannot roll or fall over.

8.4 Storage Guidelines

NOTE: Protect the product against humidity, dirt, heat sources and mechanical damage. The product must be stored at an ambient temperature from -40°C to +60°C.

8.5 Pump Design

The pump is a multistage, non-self-priming pump. The pump can be used to pump:

- Cold water
- Hot water

The pump is suitable for:

- Civil and industrial water distribution systems
- Irrigation (for example: agriculture and sporting facilities)

8.6 Improper Use

DANGER

- Do not use this pump to handle flammable and/or explosive liquids
-

WARNING

- Improper use of the pump may create dangerous conditions and cause personal injury and damage to property
-

NOTE: Do not use this pump to handle liquids containing abrasive, solid or fibrous substances, toxic or corrosive liquids, potable liquids other than water, or liquids not compatible with the pump construction materials. An improper use of the product will invalidate the warranty.

8.7 Application Limits

For the maximum working pressure and the liquid temperature limits please see the Operating Limits chart at the beginning of this manual. The data plate on the pump shows key specifications.

8.8 Installation

WARNING:

- Observe all accident prevention regulations in force
 - Use suitable equipment and protection
 - Always refer to the local and/or national regulations, legislation and codes in force regarding the selection of the installation site, plumbing and power connections.
-

DANGER:

- Do not use this unit in environments that may contain flammable/explosive or chemically aggressive gases or powders
-

Observe the following guidelines regarding the location of the product:

- Ensure that no obstructions hinder the normal flow of the cooling air that is delivered by the motor fan
 - Ensure that the installation area is protected from any fluid leaks or flooding
 - If possible, place the pump slightly higher than the floor level
 - The ambient temperature must be between -30°C and +50°C unless otherwise specified on the data plate
-

8.9 Installation Above Liquid Source

The theoretical maximum suction height of any pump is 10,33m. In practice, the following affect the suction capacity of the pump:

- Liquid temperature
- Elevation above sea level (in an open system)
- System pressure (in a closed system)
- Resistance of the pipes
- Own intrinsic flow resistance of the pump
- Height differences

NOTE: Do not exceed the pump’s suction capacity as this could cause cavitation and damage the pump

8.10 Piping Requirements

CAUTION:

- Use pipes suited to the maximum working pressure of the pump. Failure to do so can cause the system to rupture, with the risk of injury
- Make sure that all connections are performed by qualified installation technicians and in compliance with the regulations in force.

Piping Checklist:

- Pipes and valves must be sized correctly
- Pipe work must not transmit any load or torque to pump flanges.

8.11 Electrical Requirements

NOTE: Local regulations overrule these specified requirements. In case of fire fighting systems, check local regulations.

Electrical Connection Checklist:

- Check electrical leads are protected from high temperature, vibrations and collisions.
- Check that the power supply line is provided with:
 - A short-circuit protection device
 - A high sensitivity differential switch (30mA) to provide more protection against electric shock
 - A mains isolator switch with a a contact gap of at least 3mm

Electrical Control Panel Checklist

NOTE: The control panel must match the ratings of the pump. Improper combinations could fail to guarantee protection of the motor.

Check that the following conditions are met:

- The control panel must protect the motor against overload and short circuit
- Install the correct overload protection (thermal relay or motor protector).

Table 2: Control Panel Requirements

Pump Type	Protection
Single phase standard pump	<ul style="list-style-type: none"> - Built-in automatic reset thermal-amperometric protection (motor protection) - Short circuit protection (must be supplies by the installer)
Three phase pump	<ul style="list-style-type: none"> - Thermal protection (must be supplied by the installer) - Short circuit protection (must be supplied by the installer)

- The control panel must be equipped with a dry-running protection system to which a pressure switch, float switch, sensors or other suitable device is connected.
- The following devices are recommended for use on the suction side of the pump:

- When the liquid is pumped from a water system, use a pressure switch
- When the liquid is pumped from a storage tank or reservoir, use a float switch or sensors
- When thermal relays are used, relays that are sensitive to phase failure are recommended.

Motor checklist: Use cable according to rules with 3 leads (2+earth/ground) for single phase versions and with 4 leads (3+earth/ground_) for three-phase versions.

8.12 Install the Pump

See figure below for information about how to install the pump:

- 1) Piping Support
 - 2) On-Off Valve
 - 3) Flexible Pipe or Joint
 - 4) Check Valve
 - 5) Control Panel
 - 6) Do not install elbows close to the pump
 - 7) Bypass circuit
 - 8) Eccentric reducer
 - 9) Use wide bends
 - 10) Positive gradient
 - 11) Piping with equal or greater diameter than the suction port
 - 12) Use foot valve
 - 13) Do not exceed maximum height difference
 - 14) Ensure adequate submersion depth
- 1) Anchor the pump onto concrete or equivalent metal structure
 - If the liquid temperature exceeds 50°C, the unit must be anchored only by the motor bracket side and not also by the side of the inlet supporting bracket
 - If the transmission of vibrations can be disturbing, then provide vibration damping supports between the pump and the foundation.
 - 2) Remove the plugs covering the ports
 - 3) Assemble the pipe to the pump threaded connections. Do not force the piping into place.

8.13 Electrical Installation

WARNING:

- Make sure all connections are performed by qualified installation technicians and in compliance with the regulations in force.
 - Before starting work on the unit, make sure that the unit and the control panel are isolated from the power supply and cannot be energised.
-

ELECTRICAL HAZARD:

- Always connect the external protection conductor to ground (earth) terminal before making other electrical connections.
-

Enter paragraph text here

8.14 Connect the Cable

- 1) Connect and fasten the power cables according to the wiring diagram under the terminal box cover:
 - Connect the ground (earth) lead. Make sure that the ground lead is longer than the phase leads.

- Connect the phase leads.

NOTE: Tighten the cable glands carefully to ensure the protection against the cable slipping and humidity entering the terminal box.

- 2) If the motor is not equipped with automatic reset thermal protection, then adjust the overload protection according to the nominal current value of the pump (check data plate).

8.15 Commissioning, Startup, Operation and Shutdown

WARNING:

- Make sure that the drained liquid does not cause damage or injuries
-

NOTE:

- Never operate the pump below the minimum rated flow
 - Never operate the pump with the delivery ON-OFF valve closed for longer than a few seconds
 - Do not expose an idle pump to freezing conditions. Drain all liquid that is inside the pump. Failure to do so can cause liquid to freeze and damage the pump.
 - The sum of the pressure on the suction side (water mains, gravity tank) and the maximum pressure that is delivered by the pump must not exceed the maximum working pressure that is allowed (nominal pressure PN) for the pump.
 - Do not use the pump if cavitation occurs. Cavitation can damage the internal components.
-

8.16 Prime the Pump

See figure for illustration:

- 1) Fill plug
- 2) Drain plug
- 3) Funnel

8.17 Installations with liquid level above the pump (suction head)

- 1) Close the on-off valve located downstream from the pump
- 2) Remove the fill plug and open the on-off valve upstream until the water flows out of the hose
- 3) Close the fill plug

8.18 Installations with liquid level below the pump (suction lift)

- 1) Open the on-off valve that is located upstream from the pump and close the on-off valve downstream;
- 2) Remove the fill plug and use a funnel to fill the pump until water flows out of the hose;
- 3) Replace the fill plug.

8.19 Check the rotation direction (three phase motors)

Follow this procedure before startup:

- 1) Locate the arrows on the pump or motor fan cover to determine the correct rotation direction
- 2) Start the motor
- 3) Quickly check the direction of rotation through the motor fan cover
- 4) Stop the motor

- 5) If the rotation direction is incorrect, then do as follows:
 - a) Disconnect the power supply
 - b) In the terminal board of the motor or in the control panel, exchange the position of two of the three wires of the supply cable
 - c) Check the direction of rotation again

8.20 Start the Pump

- 1) Start the motor
- 2) Gradually open the on-off valve on the discharge side of the pump.
At the expected operating conditions, the pump must run smoothly and quietly. If not, refer to the Troubleshooting section.
- 3) If the pump does not start correctly in 30 seconds, then to the following:
 - a) Switch off the pump
 - b) Re-prime the pump
 - c) Start the pump again
- 4) Switch off and on the pump (for about 30 seconds of continuous running) and make sure that all the trapped air is bled out by repeating this 2-3 times.

NOTE: Make sure that the pump has bled away all the trapped air. Failure to do so can harm the product.

8.21 Maintenance

ELECTRICAL HAZARD

- Disconnect and lock out electrical power before installing or servicing the unit.
-

WARNING:

- Maintenance and service must be performed by skilled and qualified personnel only
 - Observe accident prevention regulations in force
 - Use suitable equipment and protection
-

8.22 Service

The pump does not require any scheduled routine maintenance. If the user wishes to schedule regular maintenance deadlines they are dependent on the type of pumped liquid and on the operating conditions of the pump.

Contact the local sales and service representative for any requests for information regarding routing maintenance or service.

Extraordinary maintenance may be necessary to clean the liquid end and/or replace worn parts.

8.23 Troubleshooting

Always specify the exact pump and identification code when requesting information or spare parts from the Sales or Service departments.

Table 3: Troubleshooting Table

Problem	Cause	Solution
Pump does not start	Thermo-amperometric protection in single phase version has activated	Fault will reset when the motor cools down
	Power cable	Check power cable connection is intact
	Protection device or circuit breaker triggered	Check, reset and replace any blown fuses
	Dry running protection triggered	Check tank water level, protection device and cables
Pump starts but the thermal protector is triggered after a short time of fuses blow	Power supply cable damaged, the motor short-circuits or thermal protector or fuses are not suited to the motor current.	Check and replace the components as necessary.
	Thermo-amperometric protection (single phase) or protection device (three phase) device triggered due to excessive current.	Check pump working conditions.
	Missing phase in power supply	Check power supply
	Foreign bodies/solids inside the pump - impeller jammed.	Clean the pump
Pump starts but does not deliver any liquid	Pump is sucking air	Check liquid level, check tightness of suction pipes, check operation of foot valve
	Pump is not primed correctly	Repeat priming procedure
Pump's delivery is reduced	Pump is throttled	Check for throttling of pipes
	Incorrect rotation direction	Check direction of rotation
	Pump is not primed correctly	Repeat priming procedure

9 Teknospeed Inverter

This section contains the manual for the Lowara Teknospeed variable speed drive which is used in Dutypoint products for reference of the user.

en

4.1 TKS system (TEKNOSPEED mounted on the electric pump)



Do not use the product in environments where corrosive and/or flammable powders, acids, gases, etc. are present.

Do not use the electric pump to handle dangerous or flammable liquids.

- Ambient temperature: +0°C to +40°C
- Maximum relative humidity : 50 % at + 40°C provided no condensation occurs
- Maximum height above sea level: 1000 meters
- Protection class : IP 55 (if installed on motors with at least IP55 protection)
- Maximum operating pressure : refer to the operating instructions for the electric pump
The standard version features a transmitter with 10 bar full scale (chapter 4.2)
- Temperature of pumped liquid : + 1°C to + 40 °C
- Nature of pumped liquid : water containing no chemically aggressive substances or suspended solids
- Maximum rated power of electric pump connected to the converter : 1.1 kW
- Converter supply voltage : 1 x 230 V ± 10 % 50/60 Hz
- Converter output voltage (corresponding to the motor supply voltage) :
3 x 230 V ± 10 % 12-50 Hz (these values vary according to the converter's voltage/frequency curve)
- Converter's rated input current : 6.8 A
- Converter's rated output current: 4.6 A
- Maximum number of starts per hour, evenly distributed : read the operating instructions for the electric pump

4.2 Pressure transmitter

The sensor for this transmitter is a piezo-resistive silicon element which is sensitive to pressure. It is mounted on a small flexible printed circuit (TAB) and is immersed in an oil chamber. The pressure is transmitted to the sensor through a steel diaphragm located in the oil chamber.

- Pressure range : 0 to 10 bar
- Power supply : 21 Vdc from TEKNOSPEED
- Output signal : 4 to 20 mA
- Connection : 1/4" male, made of nickel plated brass
- Electrical connector : removable, provided with 2-meter shielded cable
- Protection class : IP 55

For ambient conditions other than those specified above, please contact our Sales and Service Department.

5. Installation

Information for installers



The installation operations must be carried out by skilled and qualified personnel. Use adequate equipment and protections. Observe the accident prevention regulations in force.



Before proceeding with the installation, read these operating instructions and the manual for the electric pump.

If the product shows evident signs of damage, do not proceed with installation but contact our Customer Service Center.



Install the product in a sheltered location protected from the weather and freezing temperatures; observe the working limits in order to guarantee adequate motor cooling. For further information refer to chapters 4 and 12.



Observe all the safety standards and accident prevention regulations in force.

6. Start-up

Information for installers



The start-up operations must be performed by skilled and qualified personnel. Use adequate equipment and protections. Observe the accident prevention regulations in force.



Before starting the unit, read these operating instructions and the manual for the electric pump.

6.1 Hydraulic Connection of Electric Pump



The hydraulic connections must comply with current standards and legislation.

The product can be connected directly to the municipal water system or the water can be taken from a storage tank.

In case of connection to the municipal water system follow the regulations locally in force (issued by City, utility company, etc.). We suggest that you install a pressure switch on the suction side for deactivation of the electric pump in the event of low water system pressure (protection against dry running).



Make sure that the water system pressure added to the maximum pressure of the pump does not exceed the maximum operating pressure value (nominal pressure NP) allowed for the pump.

For example, if the system features a CA 70/33 pump we can calculate that :

Maximum head of the pump :

43 meters (equivalent to a closing contact pressure of approximately 4.3 bar)

Maximum working pressure allowed :

8 bar (NP 8)

Water system pressure (consider the maximum value):

1.5 bar

Resulting maximum working pressure :

$4.3 + 1.5 = 5.8$ less than the 8 bar limit

When using a storage tank it is necessary to install a float switch for deactivation of the electric pump in the event of low water (protection against dry running).



You must install a pressure gauge on the delivery side as it may be necessary to modify the factory settings based on the actual installation conditions.

To complete the system, flexible pipes on suction and delivery side, on-off valves on suction and delivery side, non-return valve and surge tank with diaphragm are normally installed. To avoid having to drain the system in the event that the diaphragm tank or the pressure gauge or the pressure transmitter need replacing, we advise you to install on-off valves.

If you install a check valve on the pump's delivery side, position the pressure transmitter downstream from the valve. We advise you to install a test tap to be used during the TKS system's calibration stage (chapter 6.3.3) unless a water drawing point is already present in the vicinity of the pump .

For further information refer to chapter 12.

6.1.1 Surge Tank (Diaphragm Tank)

A diaphragm tank must be installed on the delivery side of the electric pump to maintain pressure in the system when there is no water demand, in order to prevent continuous pump operation.

With the TEKNOSPEED converter there is no need for a large capacity tank. The nominal capacity of the tank, in liters, must be at least 5% of the maximum flow rate (liters per minute) of one pump, with a minimum of 8 liters of nominal capacity.

Example :

maximum flow rate of pump = 60 liters per minute

nominal volume of tank = $60 \times 0.05 = 3$ liters → 8 liters

maximum flow rate of pump = 150 liters per minute

nominal volume of tank = $150 \times 0.05 = 7.5$ liters → 8 liters

en



Make sure that the surge tank can handle the maximum pressure of the system.

Check and adjust the precharge pressure before connecting the surge tank to the system.

If the surge tank is already connected, you will have to drain the system before you check and adjust the precharge pressure. To avoid doing this, we suggest that you install an on-off valve between the connection to the tank and the system's pipe.

To determine the precharge value for the surge tank you can use the following formula:

if in bar → work pressure – 0.2 = precharge pressure

if in kPa → work pressure – 20 = precharge pressure

6.2 Electrical Connection of Pump



The electrical connections must comply with current standards and regulations.



Make sure that the type of power source, the supply voltage and frequency match the ratings of the TKS system shown in the rating plate. Provide suitable general protection against short circuits on the electrical power line.

WARNING : although the TKS system has single-phase power supply, the pump's motor is always a three-phase motor connected to 230 V. The missing phases are created by the converter. For further information refer to chapter 12.



Before proceeding with these operations, make sure that all the connections (even those that are potential-free) are voltage-free. Always disconnect the TEKNOSPEED converter from the power supply before carrying out any operations on the system's electrical or mechanical components.

After disconnection from the power source, wait at least 1 minute before carrying out any work on TEKNOSPEED to allow the condensers in the internal circuit to discharge.

6.2.1 Differential Magneto-thermal Switch

If local regulations require the installation of a differential magneto-thermal switch, make sure it is of a type that is suited to the system. Suitable switches are those having the characteristic curve for unidirectional alternate and pulsating DC fault current (type A or C).

They can be identified by the presence of the following symbol: 

6.2.2 Version with Cable and Plug

The TKS system is equipped with power cord and plug.



When installing the pump, make sure that the plug and corresponding outlet are easily accessible in case the system needs to be deactivated.

If the power cord is damaged, it must be replaced at a service center or by qualified personnel.

6.2.3 Input Filter

The TEKNOSPEED converter is equipped with an input filter according to the EMC directive.

6.2.4 Motor Overload Protection

The TEKNOSPEED converter has an incorporated overload protection which guarantees absolute protection when it is connected to motors featuring the same nominal protection as that of the converter. For lower power motors an auxiliary protection is used (see chapter 6.2.5)

6.2.5 Motor Overtemperature Protection (PTC)

Some models may feature an extra protection (thermistor) in addition to the overload protection incorporated in the converter. The thermistor (PTC) is attached to the base of the terminal board and connected through cables and mini-fastons. The corresponding dip-switch will be in the PTC Y position.

For further information refer to chapter 12.

6.2.6 Converter overtemperature protection

The TEKNOSPEED converter has an incorporated overtemperature protection.

6.2.7 Protection against dry running (float switch)

The TEKNOSPEED converter can be connected to an external device for protection against pump dry running (see chapter 6.1). The most conventional method consists in the use of a float switch installed in the suction tank.

To connect the cable of the external device you must remove the converter's radiator using a no. 5 Allen wrench (maximum torque 6 Nm). Turn the radiator upside down, paying attention to the connections with the removable terminal board. The terminal board may have to be extracted. Replace an M 16 x 1.5 plug with one of the cable glands supplied. Lay the float switch cable and connect it to the terminals corresponding to LOW 1 and LOW 2 (suitable for 0.5÷1 mm² conductors). Screw down the cable fastening plate and tighten the cable gland to secure the cable. If you connect the suction side of the pump to the municipal water system, you can use a pressure switch that opens its contact when the pressure drops below the set point.

If you are not using any device, two terminals must be connected with a jumper.



Use the slotted blade screwdriver (2.5 mm) provided with the TKS system for the connections on the converter's terminal board.

For further information refer to chapter 12.

6.2.8 External Enable Device

You can connect a switch instead of the float switch (chapter 6.2.7). This external device can be used to enable or disable the system. We recommend using a shielded cable. The stripping of the cable should allow the shielding to be in contact with the cable fastening plate.



Use the slotted blade screwdriver (2.5 mm) provided with the TKS system for the connections on the converter's terminal board.

For further information refer to chapter 12.

6.2.9 Alarm Relay

The TEKNOSPEED converter has a contact that can be used to obtain an external shutdown or malfunction signal.

This contact is closed when

- the pump is not running due to one of the following causes :
 - no voltage
 - motor overload (chapter 6.2.5)
 - motor overtemperature (chapter 6.2.6)
 - converter overtemperature (chapter 6.2.7)
 - Probe faulty or disconnected (chapter 6.2.11)
- lack of water on suction side (chapters 6.2.8 and 6.2.9)

To connect the cable you must first take the radiator off the converter using a no. 5 Allen wrench (maximum torque 6 Nm). Turn the radiator upside down, paying attention to the connections with the removable terminal board. The terminal board may have to be extracted. Replace an M 16 x 1.5 plug with one of the cable glands supplied. Lay the cable and connect it to the terminals corresponding to COM and NC (suitable for 0.5÷1 mm² conductors). Screw down the cable fastening plate and tighten the cable gland to secure the cable.

We recommend using a shielded cable. The stripping of the cable should allow the shielding to be in contact with the cable fastening plate.



Use the slotted blade screwdriver (2.5 mm) provided with the TKS system for the connections on the converter's terminal board.

For further information refer to chapter 12.

6.2.10 Serial Interface

The TEKNOSPEED converter is equipped with a serial interface that can only be used on pumping systems with two pumps.



Do not connect any wires to the COM, TX, RX terminals of the serial interface.

For further information refer to chapter 12.

en

6.2.11 Pressure Transmitter

The TKS system comes with pressure transmitter connected to the TEKNOSPEED converter's terminal board. The transmitter is equipped with a 2-meter shielded cable. If you need to wind up the cable, do not coil it but fold it.

For further information refer to chapter 12.

6.2.12 Regulation Dip-switches

The TEKNOSPEED converter is equipped with a series of microswitches (dip-switches) that determine its operating cycle.



Do not modify the factory setting; you could damage the converter or the system on which it is installed.

For further information refer to chapter 12.

6.3 Initial Start-up

6.3.1 Priming



Read the operating instructions for the electric pump.



Fill the pump and suction pipes with water before starting the system. Dry running can damage the pump.

Start the system with the on-off valve on the delivery side closed. Then open the valve gradually. When the air in the pipe has been bled off the pump will run smoothly and silently.

6.3.2 Checking the Direction of Rotation of the Motor

There is no need to check the direction of rotation of the motor since it is pre-set at the factory.

6.3.3 Operating Pressure Calibration



A pressure gauge must necessarily be installed on the delivery side as it may be necessary to modify the factory setting according to the actual installation conditions and system requirements.

The TKS system comes with a factory setting that enables it to be used.

To modify the pressure based on the actual system requirements proceed as follows:

- Increasing the pressure value

- Make sure that the system is pressurized, no user is open and the pump is off. If there are any open users you can close the on-off valve located on the pump's delivery side.
- Unscrew the plug that protects the adjusting screw.
- Turn the adjusting screw slowly to the right using a screwdriver.



Use the slotted blade screwdriver (2.5 mm) provided with the TKS system. The adjusting screw has a limited travel, less than one turn, between the minimum value (0 bar) and the maximum value (10 bar). Do not force it beyond the limits as you could damage the adjusting screw.

- The pump starts.
- Read the pressure value on the gauge and keep turning the adjusting screw until the gauge pointer reaches the desired value.
- Make sure that the pressure has stabilized at the desired value.
- If necessary, make slight adjustments by turning the adjusting screw to the right or left. If you need to lower the pressure setting, we recommend that you open a user partially (see next section "Lowering the pressure value").





Make sure that the new value you have selected is within the head range specified in the TKS system's rating plate.

- The pump stops after approx. 60 seconds. The switch-off pressure may be slightly higher than the desired value (chapter 6.4.1)

- Lowering the pressure value

- Make sure that the system is pressurized, no user is open and the pump is off.
- Unscrew the plug that protects the adjusting screw.

- Open the on-off valve located on the pump's delivery side.
 - Open a user or the test tap (chapter 6.1) partially, allowing the pressure to drop slowly.
 - The pump starts.
 - Turn the adjusting screw slowly to the left using a screwdriver.
 -  Use the slotted blade screwdriver (2.5 mm) provided with the TKS system. The adjusting screw has a limited travel, less than one turn, between the minimum value (0 bar) and the maximum value (10 bar). Do not force it beyond the limits as you could damage the adjusting screw.
 - Read the pressure value on the gauge and keep turning the adjusting screw until the gauge pointer reaches the desired value.
 - Make sure that the pressure has stabilized at the desired value.
 - If necessary, make small adjustments by turning the adjusting screw to the right or left.
 -  Make sure that the new value you have selected is within the head range specified in the TKS system's rating plate.
 - The pump stops after approx. 60 seconds. The switch-off pressure may be slightly higher than the desired value (chapter 6.4.1).
- For further information refer to chapter 12.

6.3.4 Indicator Lights

On the adhesive plate attached to top of the radiator there are three LED's with the following functions :

Steady green light	Power	Indicates that the TKS system is powered
Steady yellow light	Run	Indicates that the pump is running
Flashing red light	Alarm	Indicates an alarm has triggered

If an alarm is triggered, the red light will flash more or less rapidly depending on what has caused the system to shut down. Except for lack of water on the suction side, in all other cases the system will automatically start again after 20 seconds. If the cause of the malfunction persists, after three attempts to restart the system will definitively shut down except in case of lack of water on the suction side. For further information refer to chapters 8.1 and 12.

6.4 Product Description

Information for users

The TKS system consists of an electric pump operated by an automatic electronic control system (frequency converter known also as speed variator) that enables the delivery of constant pressure by reducing or increasing the flow rate based on the water demand.

6.4.1 Operation

The automatic electronic control system receives a signal from a pressure sensor and compares it with the set value.

When the system is pressurized the pump is switched off. Water consumption by the users determines a decrease in system pressure which causes a reduction in the value of the signal. In this case the control system starts the pump, regulating its speed until the reference or operating pressure is re-established. If the water consumption increases the control system increases the speed of the pump, while if the water consumption diminishes the control system decreases the speed of the pump. When the maximum flow rate of the pump is reached, the control system runs the pump at its maximum nominal speed.

If the pressure increases because of decreased water consumption, the value of the signal from the sensor increases; in this case the control system reduces the speed of the pump.

If there is a swift decrease in water consumption (e.g. due to sudden closing of the faucets), the control system runs the pump at minimum speed for approx. 60 seconds and then stops it. In this case the stopping pressure coincides with the set value.

en

If the water consumption decreases gradually, the system runs the pump at a slightly higher pressure for approx. 60 seconds (with transmitter full scale equal to 10 bar → + 0.2 bar), and then stops it if there is no further water consumption.

If the system is powered the green (Power) light is on.

When the pump is running the yellow (Run) light is on.

If there is a shutdown or malfunction the red (Alarm) light comes on.

If an alarm is triggered, the red light will blink more or less rapidly depending on the cause of the shutdown. Except for lack of water on the suction side, in all other cases the system will automatically start again after 20 seconds. If the cause of the malfunction persists, after three attempts to restart the system will definitively shut down.



Refer to experienced and qualified personnel for any adjustments and/or maintenance operations. Do not attempt to change the settings or open the control system.



Before using the equipment, read the manuals and store them safely.
Store the screwdriver supplied with the TKS system in a safe place.

7. Maintenance

Information for maintenance personnel

Observe the following directions if you need to carry out any service operations on the product .



Maintenance operations must be performed by qualified personnel only.



Before carrying out any maintenance operations, make sure that all the connections (even those that are potential-free) are voltage-free.



Always disconnect the TEKNOSPEED converter from the power supply before carrying out any operations on the system's mechanical or electrical components.

After disconnection from the power source, wait at least 1 minute before carrying out any work on TEKNOSPEED to allow the condensers in the internal circuit to discharge.



Read this user's manual and the operating instructions for the electric pump and diaphragm tank (if installed).

7.1 Routine Maintenance

The TKS system does not require any routine maintenance provided that the working limits described in chapter 4 are observed.

The pumps do not require any routine maintenance (read the pump's manual).

Check the air pre-charge in the surge tank, if installed, at least once a year (chapter 6.1.1).

7.2 Extraordinary Maintenance



Use adequate equipment and protections. Observe the accident prevention regulations in force. Lift and handle the pumps carefully, using suitable hoisting equipment.



Use only original spare parts to replace any worn or faulty components.

WARNING !

Although the TKS system has a single-phase power supply, the pump's motor is always a three-phase motor connected to 230 V. The missing phases are created by the converter. For further information refer to chapter 12.

8. Troubleshooting

Information for users and maintenance personnel



Read this user's manual and the operating instructions for the electric pump and diaphragm tank (if installed).



Maintenance operations must be performed by qualified personnel only.

For further information refer to chapters 7 and 12.

8.1 Visual Signaling Devices

8.1.1 Operation Signals















Green light (power)	Off	No power	○
Green light (power)	On steady	Power	●
Yellow light (run)	Off	Pump off	○
Yellow light (run)	On steady	Pump running	●

TKS_M0025_A_OT.XLS

These basic signals are integrated by the alarm signals. Therefore there could be combinations of signals such as green light on (power), yellow light off (pump off) and flashing red light (alarm).

8.1.2 Alarm signals

If an alarm is triggered the red light flashes more or less rapidly (flashing – pause – flashing) depending on the cause of the system shutdown.

Red light (alarm)	Off	No malfunction	○
Red light (alarm)	Flashing	Overcurrent shutdown	 x 2 ○  x 2
Red light (alarm)	Flashing	Converter overtemperature shutdown	 x 3 ○  x 3
Red light (alarm)	Flashing	Motor overtemperature shutdown	 x 4 ○  x 4
Red light (alarm)	Flashing	Shutdown caused by lack of water on suction side Or shutdown caused by open external switch contact	 x 5 ○  x 5
Red light (alarm)	Flashing	No signal from transmitter shutdown	 x 6 ○  x 6
Red light (alarm)	Flashing	Low voltage (undervoltage) shutdown	 x 7 ○  x 7
Red light (alarm)	Flashing	Problems at serial output (for 2-pump units)	 x 8 ○  x 8

TKS_M0026_A_OT.XLS



Be careful when servicing the system as it could restart automatically.

Shutdown caused by lack of water on suction side

If the system shuts down because there is not enough water on the suction side, it will restart automatically only if the external device re-enables its operation (float switch or pressure switch or switch → chapters 6.2.7 and 6.2.8).

Shutdown caused by other problems except for lack of water on suction side

In all these cases the system restarts automatically after 20 seconds. If the cause of the malfunction persists, the system will shut down definitively after three attempts to start.

en

To reset the system, disconnect the power supply for at least one minute.

If 10 minutes elapse after an alarm without any other malfunctions occurring, the alarm counter is reset and three new attempts are possible.

If two or more alarms are triggered simultaneously (e.g. due to motor overtemperature and lack of water), only the first malfunction signal received by the control board is signaled.

WARNING ! The converter does not have a non-erasable alarm log, we therefore recommend that you observe the flashing frequency carefully before disconnecting the power supply to the TKS system.

For further information refer to chapters 8.1 and 12.

8.2 Troubleshooting Guide

PROBLEM	PROBABLE CAUSE	POSSIBLE REMEDY
The electric pump does not start Main switch on Green light off	No power supply	Restore the power supply
	Triggering of magneto-thermal switch	Reset the switch
The electric pump does not start or it stops if it is already running The main switch is on Green light on Red light on (***) flashes)	*** = 2 flashes	
	Motor overload	Check the working conditions of the electric pump
	Damaged motor stator *** = 3 flashes	Check the motor
	Converter overtemperature	Check to see if anything is preventing the proper cooling of the converter
	*** = 4 flashes	
	Motor overtemperature (if the terminal board is equipped with the PTC protection) *** = 5 flashes	Check the working conditions of the electric pump
	Triggering of dry running	Check the water level Check the external device and the related connection cables
	*** = 6 flashes	
	Problems with the pressure transmitter *** = 7 flashes	Check the transmitter and the related connection cable
	The supply voltage is too low	
Users closed Electric pump running with speed increasing and decreasing cyclically Green light on Yellow light on Red light off	Water leaks through the non-return valve or in the system	Check the system in order to locate the leaks. Repair or replace any faulty components.
	Undersized surge tank	Check the working conditions of the electric pump
	Ruptured surge tank diaphragm	Replace the diaphragm
	Setting of work point not suitable for the system (the value is higher than the pressure that the pump is able to deliver)	Modify the system settings
Users open The electric pump does not start Green light on Yellow light off Red light off	Setting of work point not suitable for the system (the value is equal to zero)	Modify the system settings
	Setting of work point not suitable for the system (the value is lower than the minimum pressure that the pump can deliver)	Modify the system settings
The electric pump is running. There are vibrations in the pump or near the pump	Setting of work point not suitable for the system (the value is lower than the minimum pressure that the pump can deliver)	Modify the system settings
Frequent starts and stops	There may be problems with the float switch in the suction tank	Check the float switch and the tank
The electric pump is running always at maximum speed	There may be problems with the pressure transmitter	Check the hydraulic connection between the transmitter and the system

en

Triggering of general system protection	Short circuit	Check the connection cables
Triggering of differential system protection (circuit breaker)	Ground leakage	Check the insulation of the electric pump and cables

9. Spare Parts

Information for maintenance personnel

Always state the exact model identification number and construction number when requesting technical information or spare parts from our Sales and Service Center.



Use only original spare parts when replacing any faulty components.



The use of unsuitable spare parts can cause malfunctions, personal injury and damage to property.

10. Disposal

Information for installers and maintenance personnel

After installing the unit, dispose of packaging according to legislation in force; if possible, re-utilize the packaging for other purposes.

If the motor needs to be decommissioned and dismantled, observe the current legislation regarding sorted waste disposal.

11. Warranty

AGM is Dutypoint's service partner under the formation of Fluid Water Group. Dutypoint Systems standard product warranty is valid for a period of 12 months. To qualify for 24 months of cover, commissioning must be carried out by a qualified person from our service partner (AGM) within the first 12 months from the date of despatch. A servicing visit must be completed within 12 months from the date of commissioning by a qualified person from our service partner. Full terms and conditions are located on the website <https://www.dutypoint.com/terms-and-conditions>

If you need to contact us regarding any issue regarding your Dutypoint product, please contact Dutypoint or AGM customer support teams.

Dutypoint Tel: 01452 300110
 Dutypoint Email: enquiries@dutypoint.com

AGM Tel: 03335 775151
 AGM Email: service@agmservice.co.uk

TKS system composition (chapters 3 and 6.4)

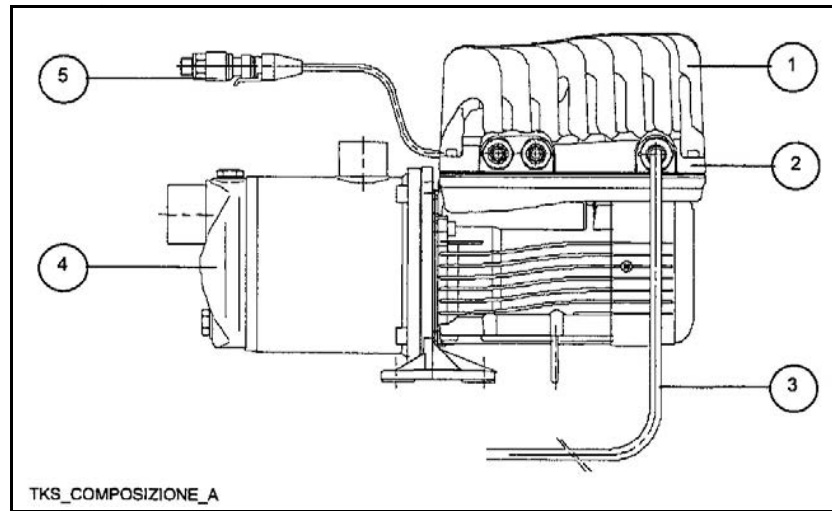

- 1 Radiator (incorporates the electronic control and command board)
- 2 Base
- 3 Cable and plug
- 4 Electric pump
- 5 Pressure transmitter

Rating plate (chapters 4 and 9)

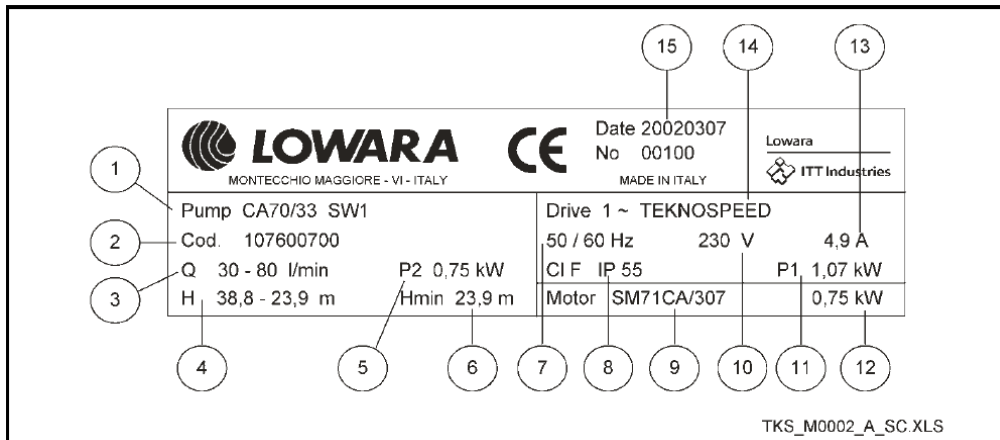

- 1 Electric pump type
- 2 Code
- 3 Flow range
- 4 Head range*
- 5 Rated power
- 6 Minimum head*
- 7 Frequency
- 8 Insulation class and protection class
- 9 Motor type
- 10 Voltage
- 11 Input power
- 12 Rated motor power
- 13 Current
- 14 Converter type
- 15 Manufacturing date and Serial number

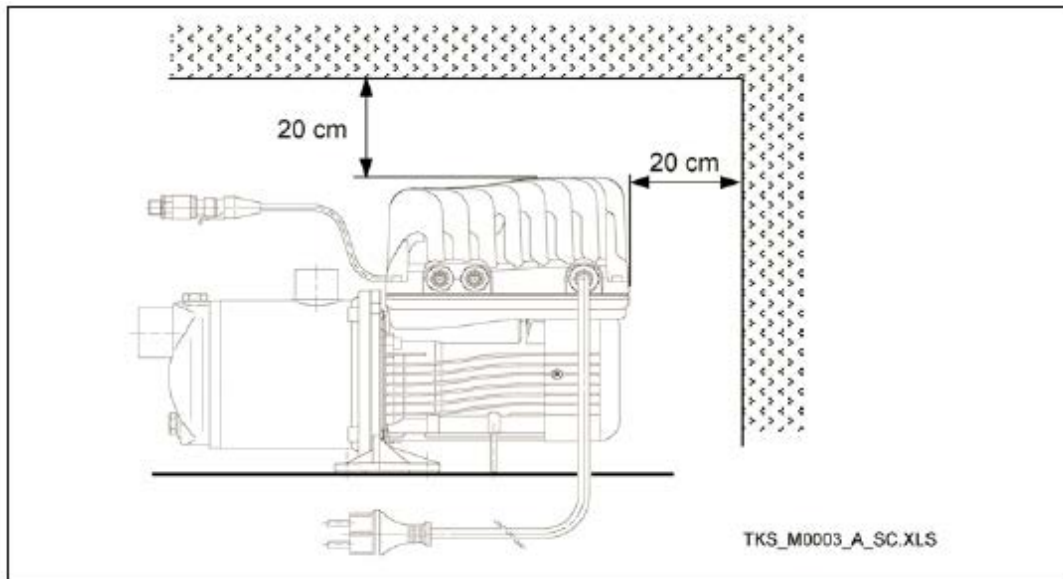

Examples of installation (chapter 6)

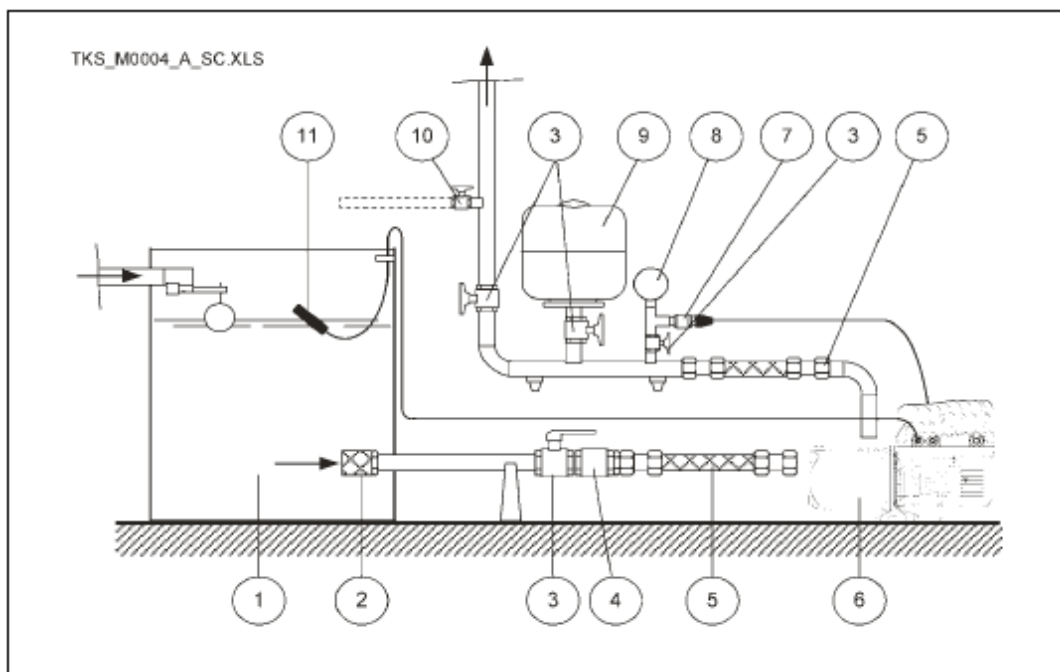

- | | |
|------------------------|---------------------------------|
| 1 Reservoir or tank | 2 Possible filter |
| 3 On-off valve | 4 Non-return valve |
| 5 Flexible pipe | 6 Electric pump with Teknospeed |
| 7 Pressure transmitter | 8 Pressure gauge |
| 9 Diaphragm tank | 10 Test tap |
| 11 Float switch | |

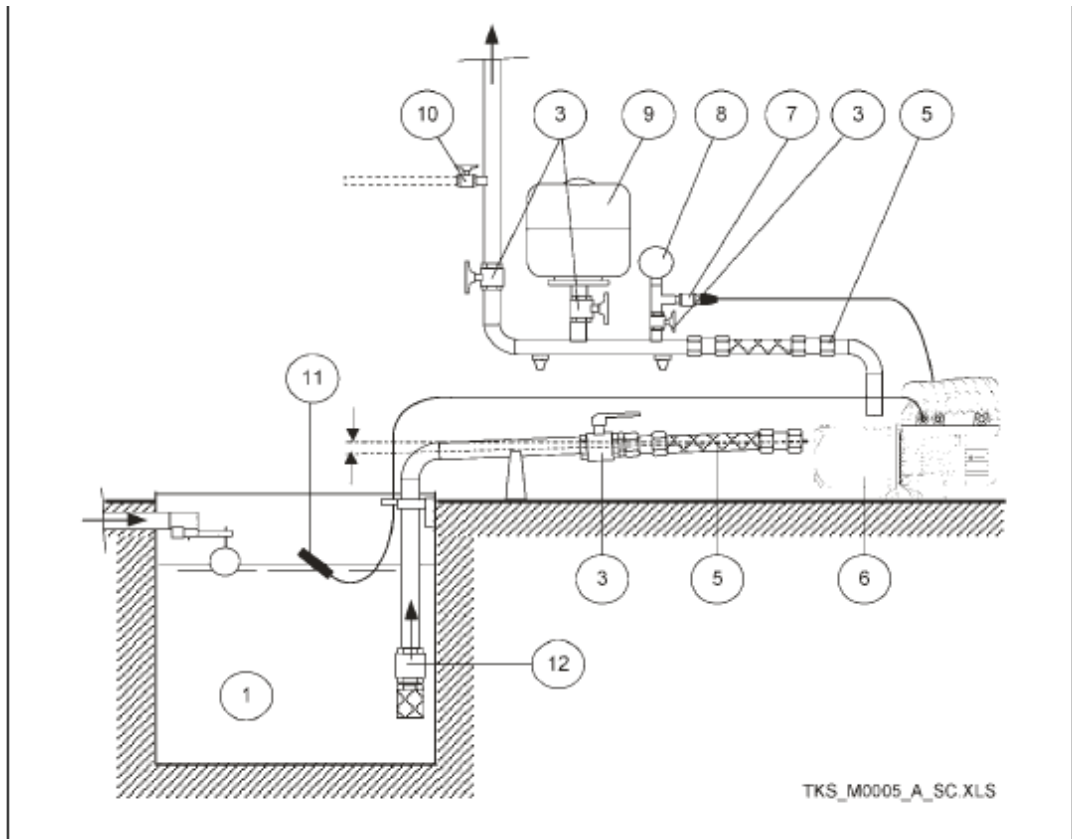

- | | |
|------------------------|---------------------------------|
| 1 Tank | 3 On-off valve |
| 5 Flexible pipe | 6 Electric pump with Teknospeed |
| 7 Pressure transmitter | 8 Pressure gauge |
| 9 Diaphragm tank | 10 Test tap |
| 11 Float switch | 12 Foot valve |

Non return valve

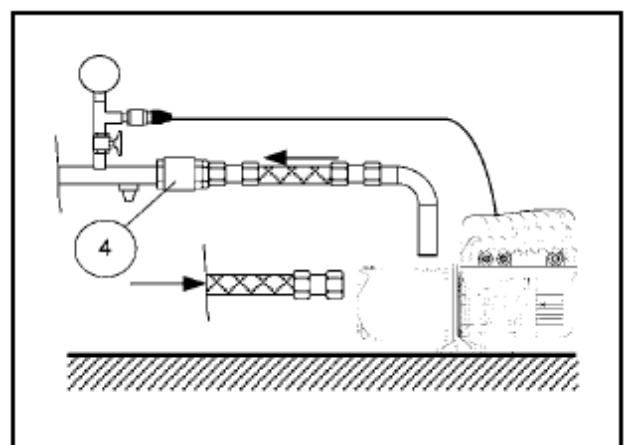
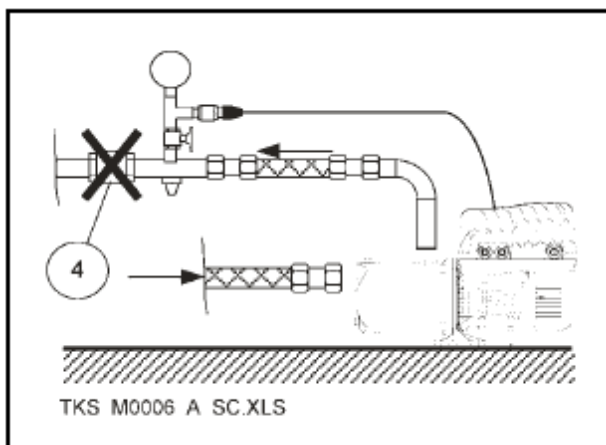

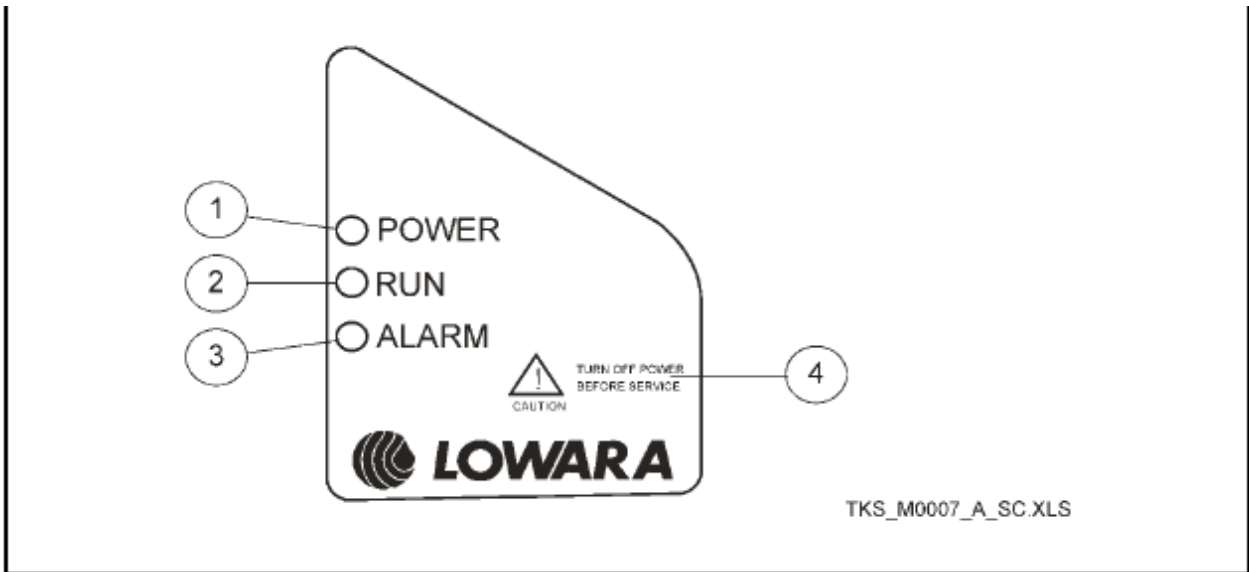

- 1 Power on indicator light
- 2 Pump running indicator light
- 3 Malfunction indicator light
- 4 Warnings

Diagram of TEKNOSPEED converter’s external connections (chapter 6)

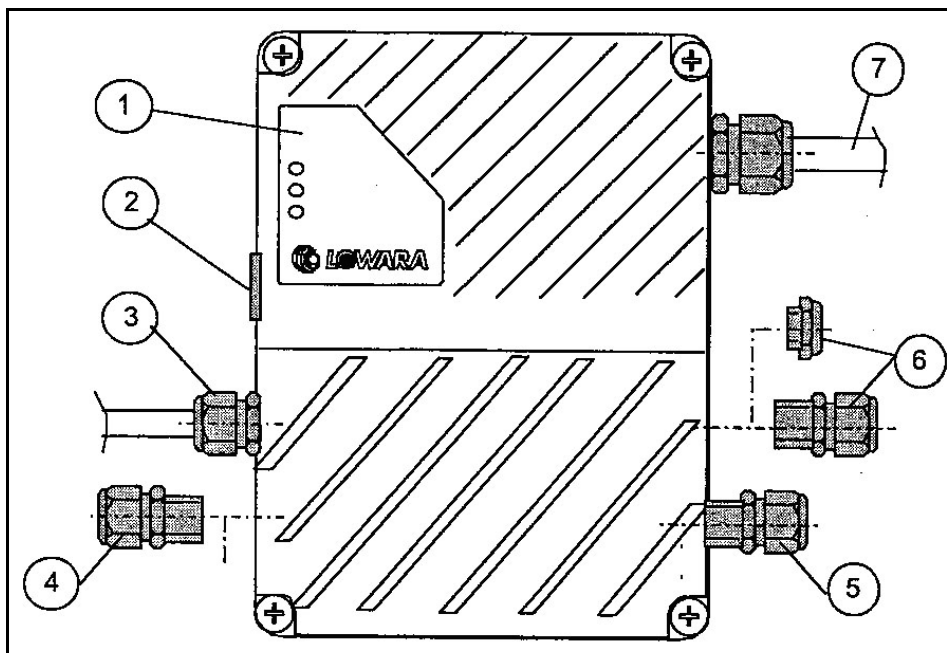

- 1 Signalling lights
- 2 Pressure adjusting screw
- 3 Inlet for pressure transmitter cable (M16 x 1.5 cable gland)
- 4 Inlet for external dry running protection device cable (M16 x 1.5 cable gland or plug)
- 5 Inlet for serial interface cable (M16 x 1.5 cable gland or plug)
- 6 Inlet for malfunction signalling relay cable (M16 x 1.5 cable gland or plug)

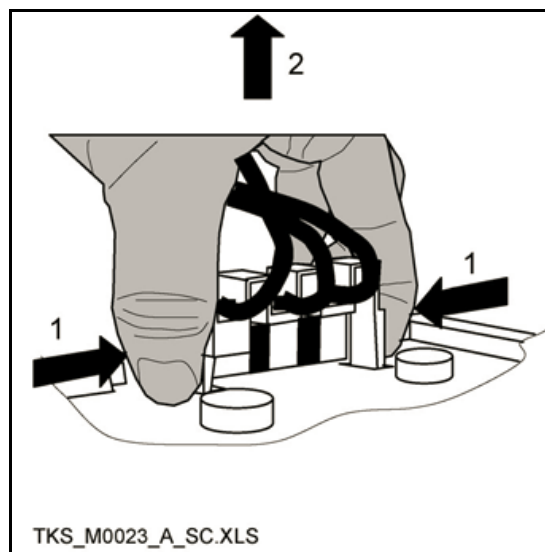
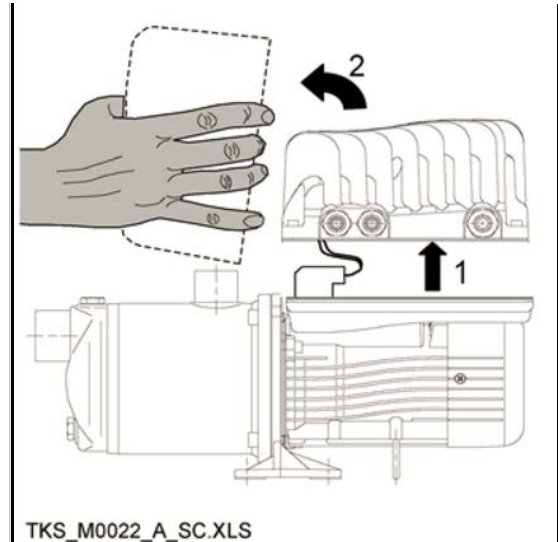
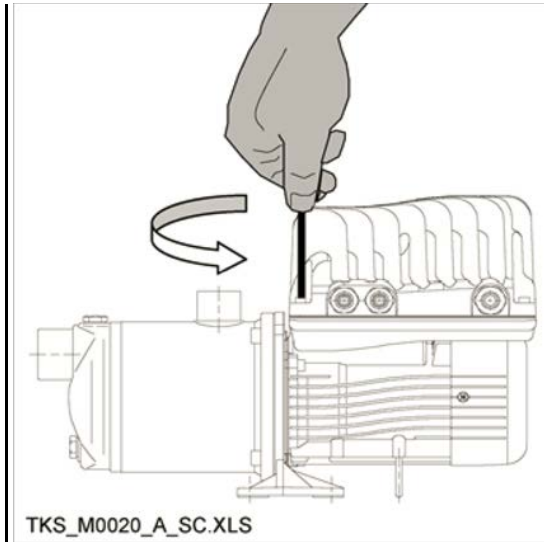

How to fasten the cable shielding (chapters 6.2.8, 6.2.9, 6.2.11)

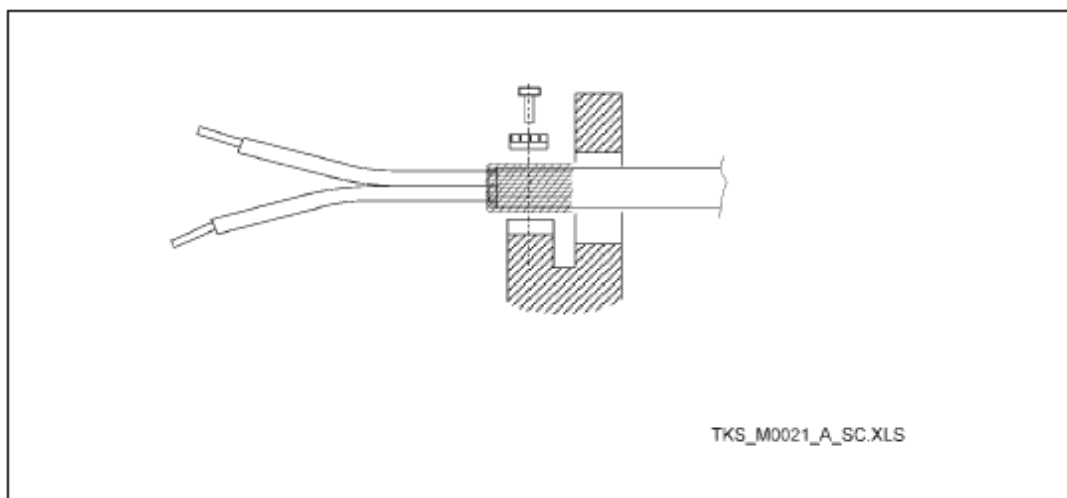

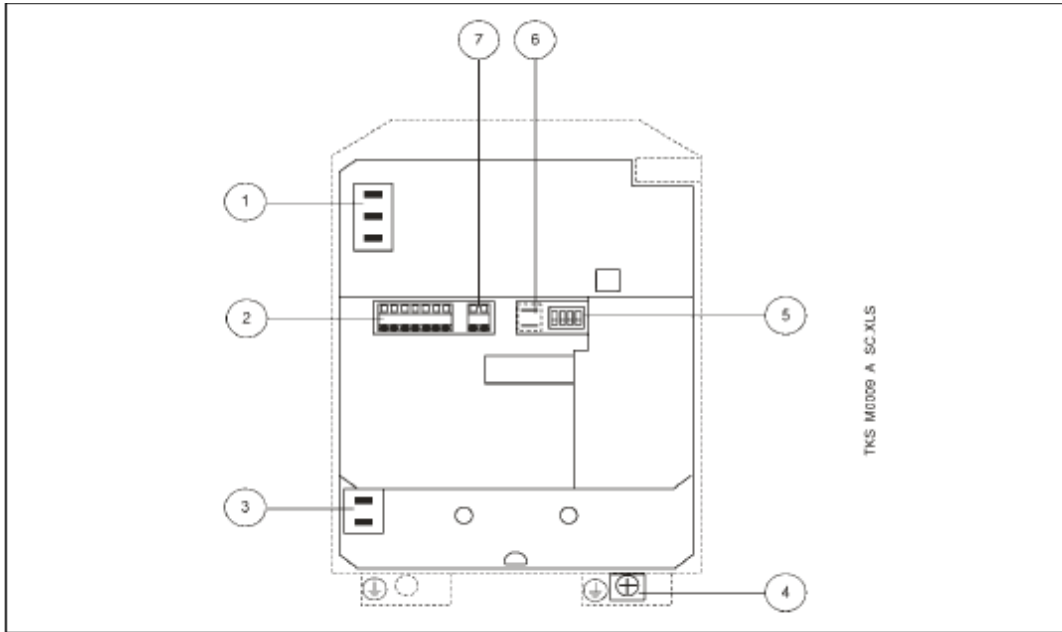

- 1 6.35 mm Faston male connectors for motor terminal board cables
- 2 Terminal board for transmitter, float switch, serial interface (IN / OUT)
- 3 6.35 mm Faston male connectors for phase and neutral (power cord)
- 4 Ground screw for power cord
- 5 Operating cycle adjustment dip-switch
- 6 2.8 mm Faston male connectors for thermistor
- 7 Terminal board for malfunction signals (OUT)

Auxiliary terminal board

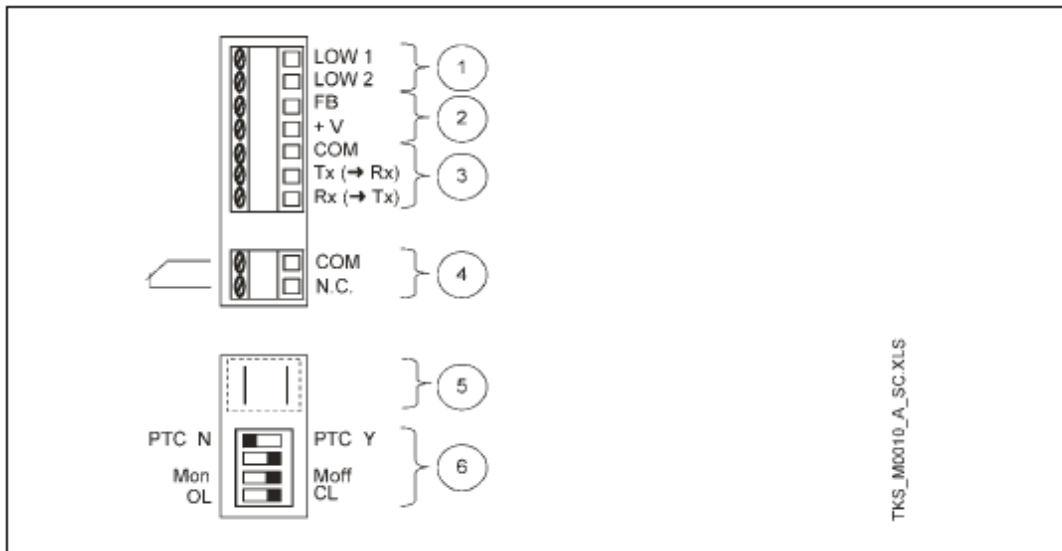

- 1 Connection to external device for dry running protection (chapters 6.2.7 and 6.2.8)
- 2 Connection to external transmitter (chapter 6.2.11)
- 3 Serial interface connection (chapter 6.2.10).
- 4 Connection to alarm relay (chapter 6.2.9)
- 5 Connection to motor over temperature protection - PTC (chapter 6.2.5)

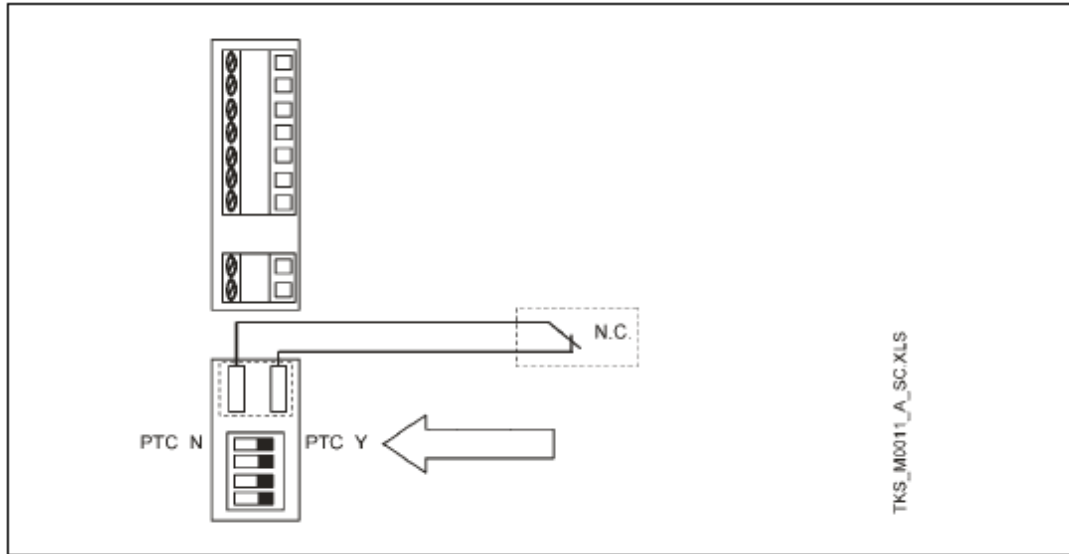

Connection to external device for dry running protection (chapters 6.2.7 and 6.2.8)

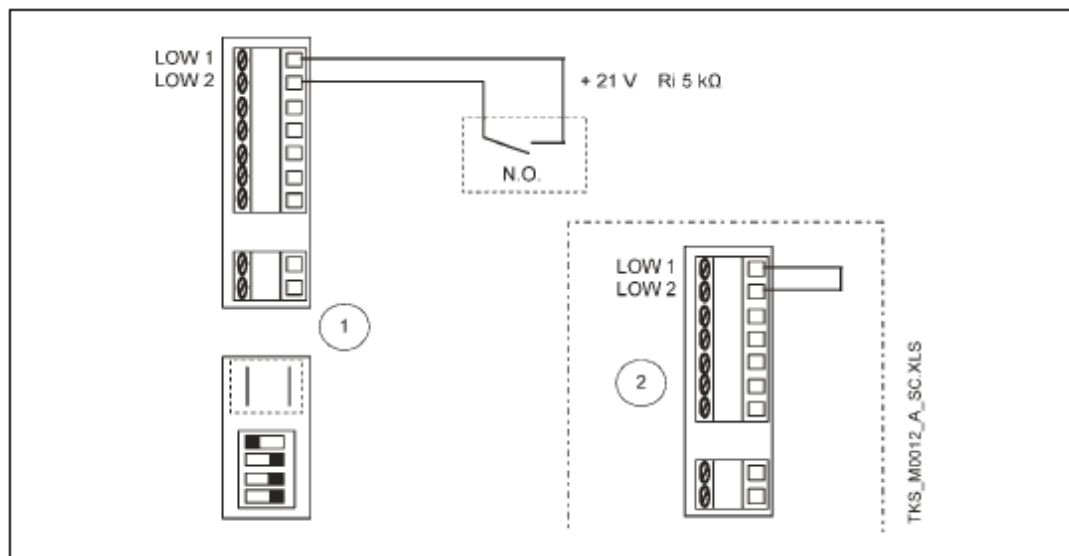

1 Float or pressure switch

2 No external device

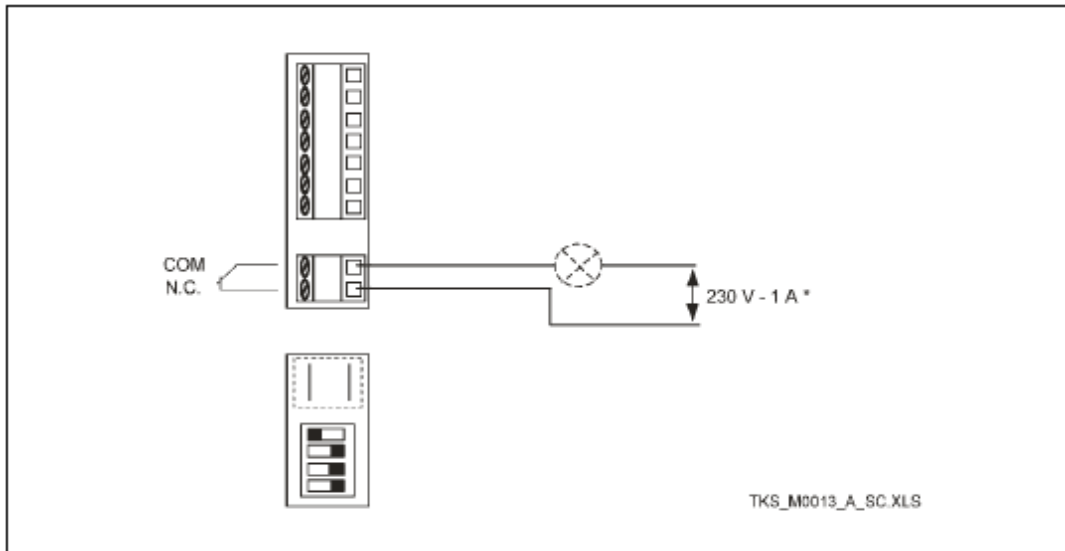

* maximum 230 Vac, maximum 1 A of resistive load only

Serial interface connection (chapter 6.2.10)

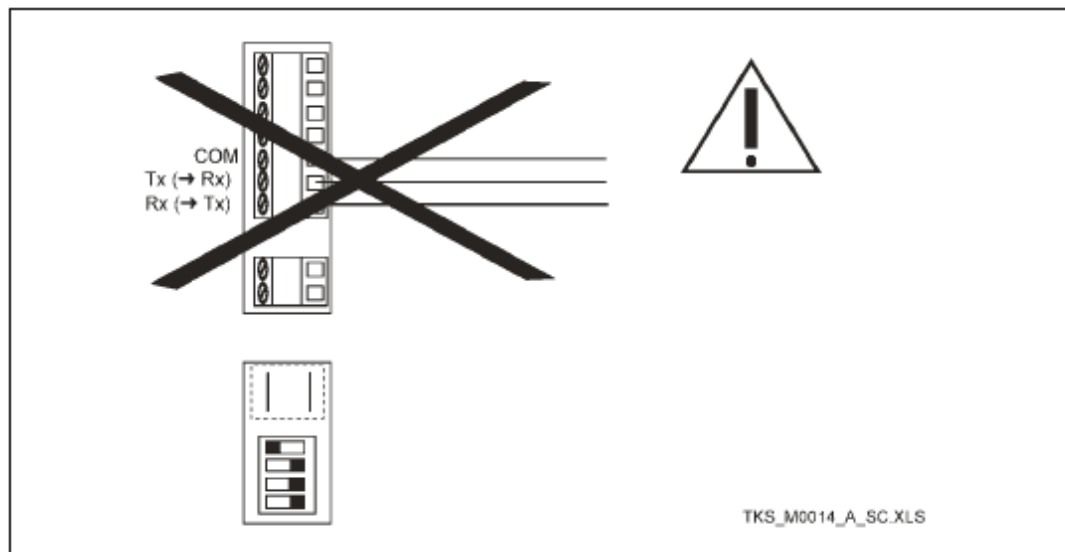

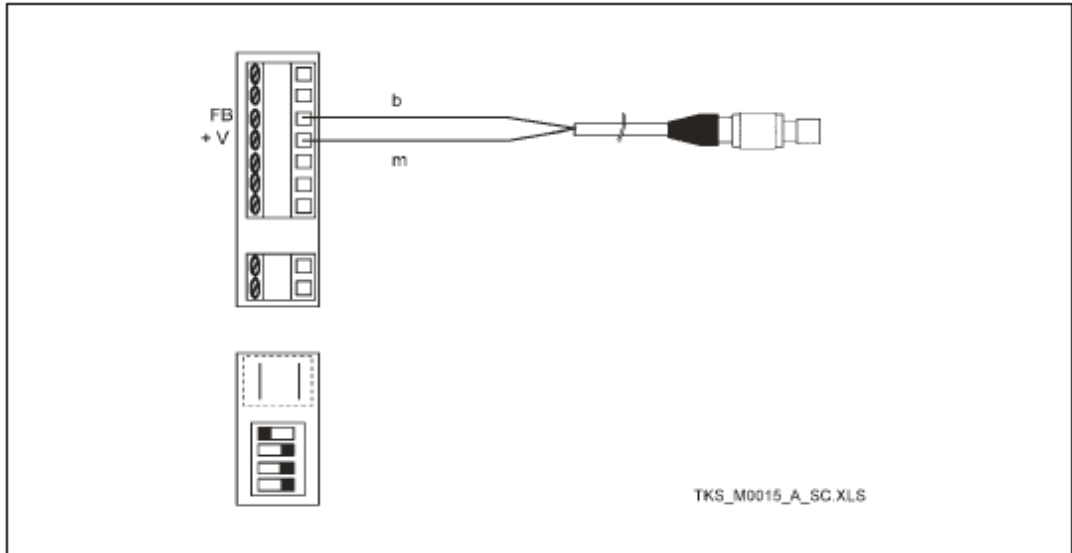

b = white
m = brown

How to fold the external transmitter cable (chapter 6.2.11)

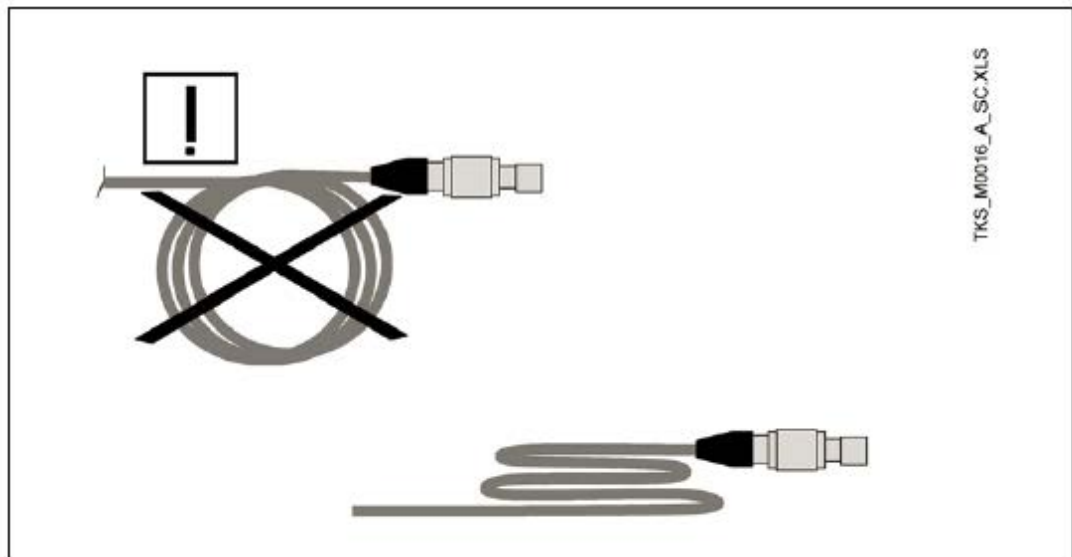

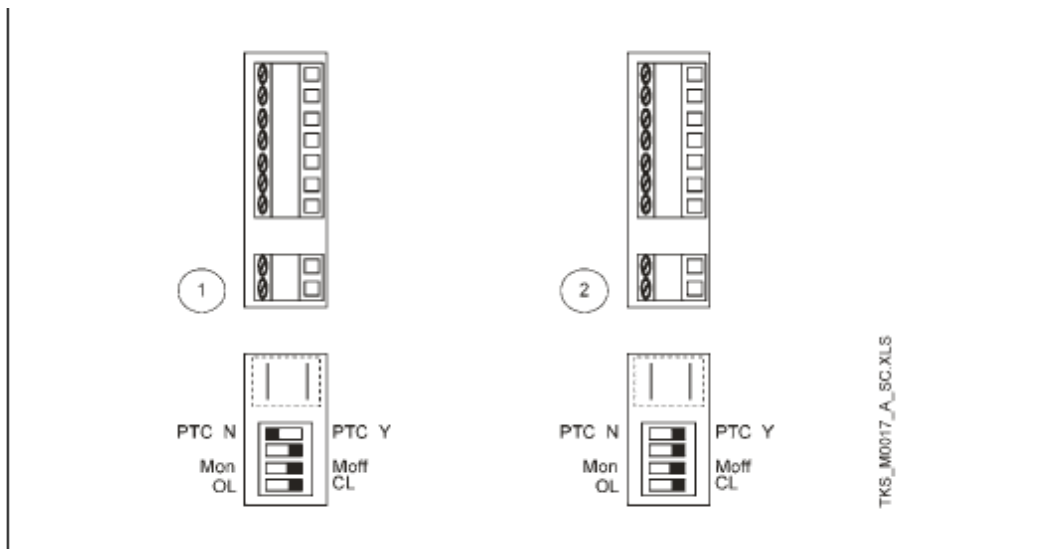

- 1 Version without PTC protection
- 2 Version with PTC protection

Factory settings modification procedures (chapter 6.3.3)

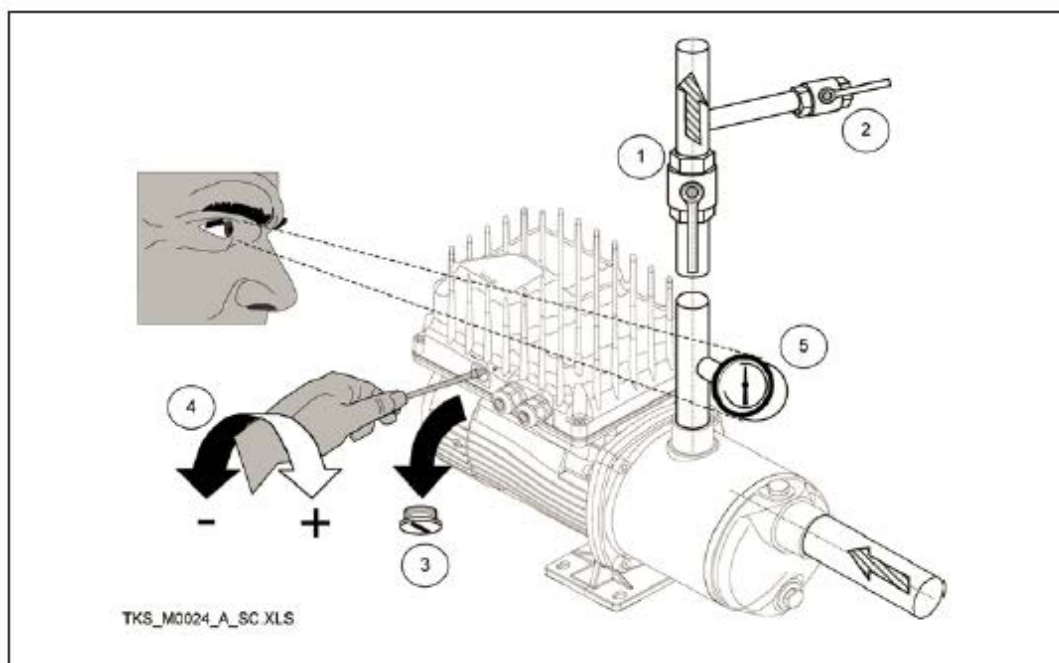

- 1 On-off valve on delivery side
- 2 Test tap
- 3 Adjusting screw protection plug
- 4 Adjustment screwdriver
- 5 Pressure gauge for reading of system pressure value

TKS/.....	PRESSIONI - PRESSURES - PRESSIONS - DRUCKWERTE - PRESSOES - DRUKWAARDEN	
	kPa	bar
...BG7	300	3,0
...BG11	350	3,5
...CEA80/5	250	2,5
...CEA120/5	200	2,0
...CA70/33	300	3,0
...CA70/44	400	4,0
...2HMZ3T	150	1,5
...2HMZ5T	250	2,5
...2HMZ7T	400	4,0
...4HMZ4T	150	1,5
...4HMZ5T	200	2,0
...4HMZ9T	350	3,5
...SV206F07T	350	3,5
...SV208F11T	500	5,0
...SV404F07T	200	2,0
...SV407F11T	350	3,5

TKS_M0018_R_OT.XLS

Basic structure of TEKNOSPEED frequency converter (chapter 6.4)

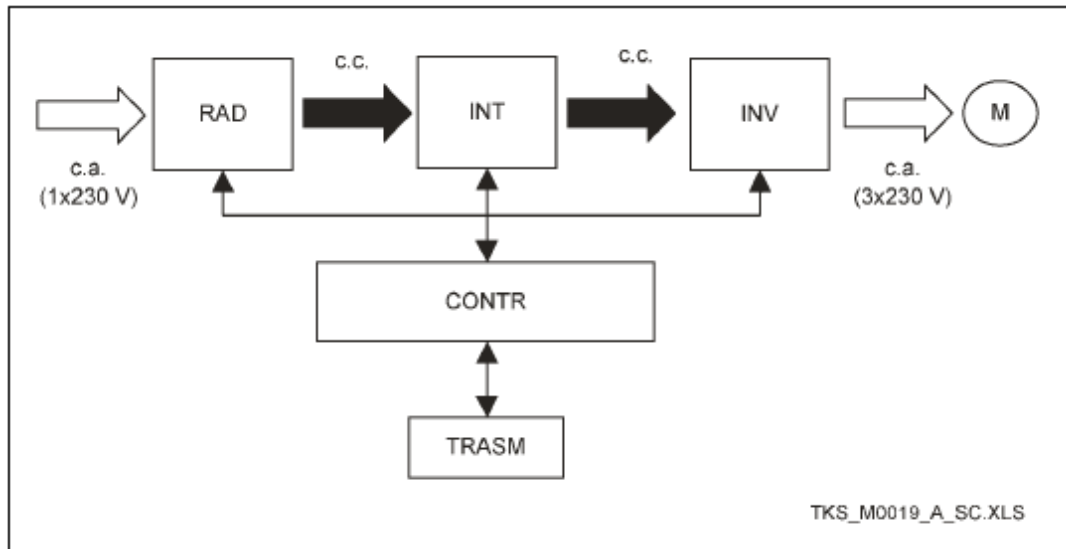

TKS_M0019_A_SC.XLS

- c.a. Alternate current
- c.c. Direct current
- RAD Rectifier
- INT Intermediate circuit
- INV Inverter
- MOT Motor
- CONTR Control circuit
- TRASM Transmitter

Lowara srl, with headquarters in Montecchio Maggiore - Vicenza – Italy, hereby declares that the products described below

**TKS series electric pumps equipped with Teknospeed frequency converter,
pressure transmitter with two-meter cable and power cord with plug**

comply with the provisions of the following European Directives and with the regulations transposing them into national law

- Machinery 98/37/EEC
 - Low Voltage 73/23/EEC and subsequent amendments
 - Electromagnetic Compatibility 89/336/EEC and subsequent amendments
- and with the following technical standards
- EN 60335-2-41, EN 55014-1, EN 55014-2, EN 61000-3-2, EN 61000-3-3

Montecchio Maggiore – Italy, 31.10.2002

Amedeo Valente
(Director of R&D and Engineering)

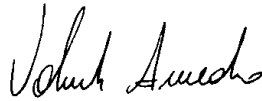

10 EC Declaration of Conformity

We: Dutypoint Limited

Of: Shepherd Road, Gloucester, GL2 5EL, United Kingdom

In accordance with the following directives:

- 2014/65/EU: The Low Voltage Directive
- 4104/30/EU: The Electromagnetic Compatibility Directive
- 2006/95/EU: The Machinery Directive

Hereby declare that the equipment:

Description	ElevaTANK Frame-Mounted Cold Water Tank and Cold Water Booster Set
Model Code	ETxxxxxx-VG2-xxHMxx-LZM

Is in conformity with the applicable requirements of the following documents:

- EN 809:1998+A1:2009: Pumps and pump units for liquids - Common safety requirements
- EN 60204-1:2006: Safety of machinery - Electrical equipment of machines - Part 1: General requirements
- EN ISO 12100:2010: Safety of machinery - General principles for design
- EN 61000-6-2:2005: Electromagnetic compatibility (EMC) — Part 6-2: Generic standards
- EN 61000-6-4:2007: Electromagnetic compatibility (EMC) — Part 6-4: Generic standards

I hereby declare that the equipment described above has been designed to comply with the relevant sections of the above referenced specifications. The unit complies with all applicable Essential Requirements of the Directives.

Dutypoint

Unit A,
Quedgeley West
Business Park,
Gloucester
GL2 4PA
United Kingdom

T: +44(0) 1452 300110
W: www.dutypoint.com